

Hellenbrand

 **IRON CURTAIN™**
SYSTEM



For systems manufactured after October 1997

Owner's Manual

©2003

Manufactured by:
HELLENBRAND, INC.
404 Moravian Valley Road • PO Box 187
Waunakee, Wisconsin 53597
Phone: 608-849-3050 • Fax: 608-849-7398
Web: www.hellenbrand.com • Email: info@hellenbrand.com

Congratulations on your purchase of one of the finest water treatment systems available today – the Iron Curtain System. This patented, non-chemical filter system, when properly applied will remove iron, manganese and/or hydrogen sulfide from your water supply. The Iron Curtain has been third-party tested by the Water Quality Association. An optional "Type A" filter also corrects low pH water.

This owner's manual is designed to assist owners and installers with the operation, maintenance, and installation of your new iron removal system. It is our sincere hope that this manual is clear, concise, and helpful to both owner and installer. We have included detailed instructions of general operating conditions, pre-installation, installation, start-up, and timer settings.

Questions? Should you have any questions regarding the installation, operation or servicing of this system, please **contact the dealer you purchased this system from**. Your dealer will be familiar with your particular situation, your water conditions, etc. and should be able to address your concerns promptly and efficiently.

TABLE OF CONTENTS

Installation Data	3
Air Recharge & Air Bleed-Off Valve Fitting Connection Assy.	3
Aeration Head Fitting Connection	3
Principle of Operation	4
Operation of Aeration Pump	4
Advantages Over Other Systems	4
Operating Conditions	5
General Application Guidelines	5
Pre-Installation Check List	6
Installation Instructions	6
Start-up	6-7
Regeneration Frequency	7
Specifications	7
Type A Iron Curtain Systems	7
Instructions for Adding IC pH Correction Media	7-8
Installation Diagrams	8-9
How to Set Timer	9
How to Set Regeneration Time	10
How to Manually Regenerate Your Water Filter	10
How To Manually Advance Control Center	10
How to Set Regeneration Cycle Program	11
Iron Curtain System Diagram	12
Iron Curtain Wiring Diagram	12
Iron Curtain Timer Assembly	13
Iron Curtain Control Drive Assembly	14
Iron Curtain Aeration Pump Diagram	15
Iron Curtain Aeration Pump Repair Instructions	16
IC-10 Series Control Valve Assembly	17
IC-12 Series Control Valve Assembly	18
Instructions for Replacing Piston Assy. & Seal Kit	19-21
Iron Curtain Flow Diagrams	22-24
Troubleshooting	25-26
Winterizing Iron Curtain Systems	27
Iron Curtain Limited Warranty	28

INSTALLATION DATA

Date of Installation _____ Model No. _____

Address of Installation _____

Installed By _____

Raw Water Test: Iron _____ Manganese _____ pH _____ Hydrogen Sulfide _____
 TDS _____ Iron Bacteria _____ yes _____ no Tannins _____

Automatic Regeneration: Every _____ Days

Influent Flow Rate @ 25 PSI _____ Gallons Per Minute (gpm)

Regeneration Program Settings*

Cycle	Factory Preset Setting	Number Pins/Spaces	Program Wheel Location	Customized Setting
Backwash	12 minutes	6 pins	10 - 20	_____ minutes
Air Recharge Cycle	18 minutes total	9 spaces	22 - 38	_____ minutes
Pre Bleed-off	4 minutes	2 spaces	22 - 24	_____ minutes
Air Recharge/ Bleed-off	10 minutes	5 spaces	26 - 34	_____ minutes
Air Pump Run Time	10 minutes	5 pins extending out back of program wheel	0 - 8	_____ minutes
Post Bleed-off	4 minutes	2 spaces	36 - 38	_____ minutes
Rapid Rinse	6 minutes	3 pins	40 - 44	_____ minutes
Cycle Advance	4 minutes	2 spaces	46 - 48	_____ minutes
Cycle Shut Off	4 minutes	2 pins	50 - 52	_____ minutes

*Refer to page 11 for instructions if altering factory settings.

Note: Five pins extending out back of program wheel (0 - 8 program wheel location) are synchronized with bleed-off spaces 26 - 34.

Air Recharge & Air Bleed-Off Valve Fitting Connection Assembly

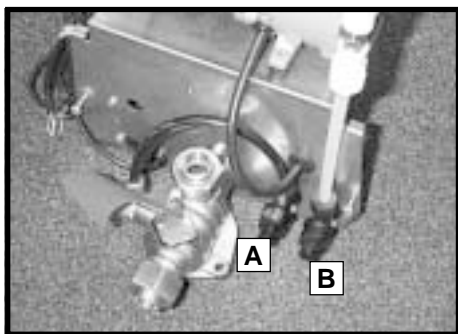
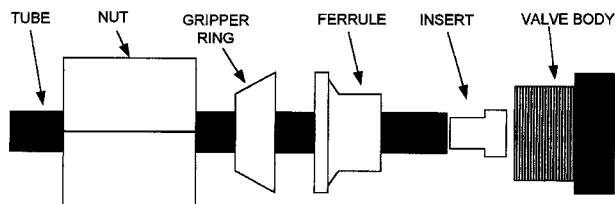

- A. Iron Curtain Bleed Off Valve - PN 22-55
- B. Iron Curtain Air Recharge Valve - PN 22-54

Aeration Head Fitting Connection

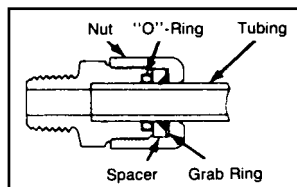

Fast & Tite Fittings, Pictures 1 - 5

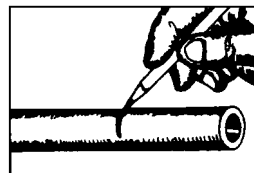

2. Mark from end of tube the length of insertion. (See Table)

Tube Size	Insertion length without Tube Support	Insertion length with Tube Support
1/4 O.D.	9/16"	5/8"
5/16 O.D.	9/16"	5/8"
3/8 O.D.	3/4"	13/16"
1/2 O.D.	13/16"	7/8"
5/8 O.D.	1"	15/16"

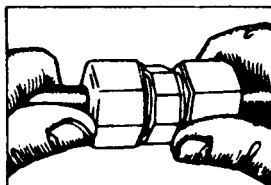

4. Moisten end of the tube with water. Push tube STRAIGHT into fitting unit it bottoms on the fitting's shoulder. Tighten nut by hand. Additional tightening should not be necessary, but 1/4 additional turn may be added if desired. DO NOT OVER-TIGHTEN nut or threads will strip and the fitting will not function properly. A proper assembly will not show the insertion mark extending beyond the nut. If the insertion mark is visible, then steps 1 thru 4 must be repeated.

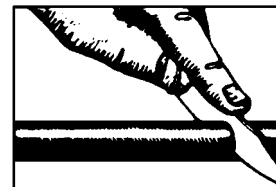

1. Cut the tube squarely and remove any burrs.

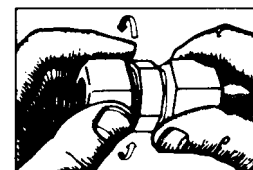

3. Loosen nut on fitting until three threads are visible. Fittings for glass tubes must be disassembled and the grab ring removed.

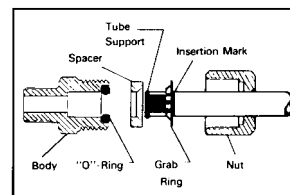

5. When using clear vinyl tubing, it is necessary to use a "TS" tube support. Disassemble the fitting and place the nut, grab ring at the insertion mark as shown. Seat the O-ring in the body then proceed with step 4.

IRON CURTAIN

Iron Filtration System

Aeration/precipitation/multi-media filtration for:

1. Iron Reduction/Removal
2. Manganese Reduction/Removal
3. Hydrogen Sulfide Reduction/Removal

A special Type A filter also provides pH adjustment on water supplies with a pH from 6.0 or greater.

Principle of Operation

The Iron Curtain System uses a **three step process of oxidation, precipitation, and mechanical filtration** for the reduction/removal of iron, manganese, and hydrogen sulfide. The process of how the Iron Curtain System does each one of these separate procedures is the key to the successful results this product has obtained in the market place. There are **three main components that make up the Iron Curtain System**. They are:

1. IC Control Center w/Aeration Pump
2. Aeration Tank
3. Multi-Media Depth Filter

1 The first step in any oxidizing process is to bring the raw water into intimate contact with a strong oxidant. This will begin to convert the dissolved element such as iron or manganese to a physical particle or nonsoluble precipitate. The least expensive environmentally-safe oxidant is oxygen (O₂)—air. To do this, the Iron Curtain System makes the water spray through a regulated head of air in the aeration tank.

2 The second step in this three step process of oxidation - precipitation - filtration is to provide adequate reaction or contact time for the precipitation to go to completion. This allows time for the iron and/or manganese particles to become large enough to filter out. The aeration tank with the Iron Curtain System allows for several minutes of contact time at the rated service flows, compared to only seconds on other systems.

It should be noted that this reaction time will also be affected by temperature; the warmer the water the faster the reaction. This reaction time may also be affected by the presence of organic material (such as tannins). *If tannins are present, field tests have shown that they will not be removed and will also hinder the ability of this system to effectively remove iron, manganese, and/or hydrogen sulfide. Installation of this system on water supplies with more than 0.5 ppm of tannins will void warranty.*

3 The third and final step is the removal of the precipitates from the water. The WQA Water Filtration Study Guide states:

“The ideal filter bed would be one with large grains at the top to prevent the formation of a surface cake and to provide large pores for coarse particles and small grains at the bottom to entrap smaller particles. This allows the entire depth of the bed to be used as a filter. This also allows for longer filter runs and faster flow rates. Unfortunately, such an ideal bed, when consisting of a single media is not possible,

the way to solve this problem is to use layers of media.”

The advantages of a multi-media bed are:

1. Longer runs between backwash times.
2. Caking of the bed and breakthrough of turbidity are virtually eliminated.
3. Much higher service flow rates per square foot.
4. Higher degree of clarity because of the heavier, finer filter media in the bottom.

The standard Iron Curtain System uses five layers of filter media. The top layer is made up of large, lighter weight particles. The second layer contains a slightly heavier media. The third layer contains a much heavier media. The fourth layer contains an even heavier media. The fifth layer is a special support bed to retain filter media so it does not pass through the distribution system, and allows an even distributed flow of backwash water.

Operation of Aeration Pump

The Iron Curtain System introduces air into the aeration tank and bleeds off the old head of air automatically. Following the backwash cycle, both the air recharge valve and the air bleed off valve open, allowing water and/or air to bleed out of the aeration tank. After approximately 4 minutes, the aeration pump automatically starts pumping a fresh head of air into the aeration tank for approximately 10 minutes. After the pump shuts off, the air recharge and air bleed off valves remain open for an additional 4 minutes to allow any excess air and/or water to bleed off to drain.

Advantages Over Other Systems

1. Tested and validated by WQA under their S-200 Standard.
2. Uses no chemicals or salt.
3. Eliminates need for air injectors, venturis, or micronizers.
4. No floats or air volume controls to regulate air volume in aeration tank which “foul” from iron.
5. Two-tank system consisting of a pressurized aeration tank and multi-media depth filter.
6. 110V aeration pump to recharge aeration tank.
7. Can be used on shared wells, municipal water supplies, or with buried pressure tanks without additional equipment.
8. Higher service flow rates.
9. Better filtration results.
10. U.S. Patent #B1 5,096,596

Operating Conditions

The Iron Curtain System has been validated by the WQA under their S-200 Filter Standard for the reduction/removal of iron, manganese, and/or hydrogen sulfide. The concentration limits listed below reflect the maximum individual limit that each contaminant was tested for separately without any interference of other contaminants in the influent water.

In reality, however, we know that these contaminants may be present in combination which may limit the filter's ability to remove these contaminants in higher concentrations. In some cases, individual sellers of this equipment have had success removing higher concentrations of contaminants—iron, for example—above the limitations we have listed. If you are considering the installation of this system for the reduction/removal of iron, manganese and/or hydrogen sulfide beyond the printed operating conditions below, we recommend that you consult the manufacturer for proper application. Installation of this system under these circumstances may void part(s) and/or all of the system warranty.

pH—The pH level of the influent water must be 7.0 or higher unless you have a Type A filter, which will work on a pH of 6.0 to 7.0.

Iron — This system is rated for a maximum of 10 ppm of ferrous (clear water) and/or ferric (red water) iron.*

Iron Bacteria — If iron bacteria are present; more frequent service may result, the life of the Iron Curtain system may be limited and the system may be unable to properly remove iron. **By properly controlling the iron bacteria with chlorine or other approved methods for bacterial reduction, the Iron Curtain System will function properly. One option is to control iron bacteria within the Iron Curtain is chlorine injection during the regeneration cycle. In some instances, continuous chlorination of the water supply may be needed.**

Hydrogen Sulfide — Often referred to as rotten egg odor, hydrogen sulfide will be reduced significantly on water supplies containing less than 10 ppm. Past installations have shown that hydrogen sulfide levels from 2.0 - 10.00 ppm will require use of the Iron Curtain Remote Control Center and/or larger aeration assembly. The Iron Curtain Remote Control Center has an independent timer program which recharges the aeration assembly with fresh oxygen up to six times per day, with the filter(s) being regenerated with their own independent timer.*

Manganese — Limit 2.0 ppm; amounts present over 2.0 ppm will gradually prevent iron removal. If manganese is present, a larger filter should be installed with more frequent backwashing. Note: For optimum manganese reduction, pH should be greater than 8.5.*

Organic Matter (Tannins) — The presence of organic matter such as tannins may tie up iron or manganese preventing the oxidation/filtration process from occurring. *The presence of organics such as tannins above 0.5 ppm voids any claims for this system to perform as stated above. In some applications, tannin levels below 0.5 ppm or the presence of other organics may hinder the operation of this system.*

Chlorine — The presence of chlorine in the raw water supply ahead of this system should be limited to a maximum of 1.0 ppm residual and preferably 0.5 ppm or less when fed continuously.

Total Dissolved Solids (TDS) — While TDS does not directly affect iron removal, it is a good indicator of potential interference. Most waters have TDS less than 500 and generally present no problems to iron treatment. If any ion becomes excessive, it can possibly cause failure of iron removal. *A TDS more than 750 ppm voids any claims for this system to perform as stated above.**

*For application parameters outside the specified operating conditions or additional information regarding the listed items contact your dealer.

General Application Guidelines for Residential Iron Curtain Systems

Iron Applications

0.3 - 3.0 ppm Iron	Standard IC System, sized for application service flow rate, set to regenerate every three days.
3.0 - 6.0 ppm Iron	Standard IC System, sized for application service flow rate, set to regenerate every other day.
6.0 - 10.0 ppm Iron	Standard IC System, sized for application service flow rate, set to regenerate every day.
10+ ppm Iron	Consult Factory

Note: Manganese will also be reduced if the pH of the water is 8.5 or greater.

Hydrogen Sulfide Applications

Hydrogen Sulfide (H₂S) consumes 7 times the amount of oxygen to oxidize than iron does. Therefore, for Hydrogen Sulfide Applications, we use the following guidelines:

0 - 1 ppm H ₂ S	Standard IC System, Aeration tank sized for 2 minutes contact time.
2 - 4 ppm H ₂ S	IC System using Remote Control Center with Pump, Aeration tank sized for 2 minutes contact time. Standard IC System could be used for these applications, however the system must be set to regenerate every day to replenish air in aeration tank. During high usage times, available oxygen in the aeration tank could be consumed, allowing bleed through of H ₂ S. By using the Remote Control Center with Pump, the air in aeration tank is replenished every 4 hours and filter(s) can be set to regenerate everyday, every other day or every three days.
5 - 8 ppm H ₂ S	IC System using Remote Control Center with Pump, Aeration tank sized for 3 minutes contact time. Use an Iron Curtain Plus bed for optimum results.
8-10 ppm H ₂ S	IC system using Remote Control Center with Pump, Aeration tank sized for a minimum of three minutes contact time, Iron Curtain Plus bed.

Also note that with TDS over 750 ppm, additional contact time is recommended. Consult Factory.

Pre-Installation Check List

Water Pressure: A minimum of 30 psi at a predetermined flow rate is required to backwash the filter properly, with a maximum of 70 psi to be used.*

Actual Influent Flow Rate: (Water available from well pump, service inlet, etc.) The actual pumping rate must exceed the backwash rate for the model of filter selected at a minimum of 30 psi. See actual backwash rates in the Specifications section on page 7.

Electrical Requirements for Filter Control: A continuous 110 volts is required to cycle the controls and aeration pump. Make certain the electrical supply is always on and cannot be turned off with another switch.

Existing Plumbing: The condition of the existing plumbing should be free from lime and iron build-up. Piping that is heavily built-up with lime and/or iron should be replaced.

Equipment Location: See Figures 1, 2 & 3 on page 8&9.

Location of Aeration and Filter Tank: See Figures 1, 2 & 3 on page 8&9. These two tanks should be installed after the pressure tank and as close to each other as practical. If you want to filter outside hosebibs, be sure the filter system is properly sized to handle the flow rates required for extended periods of time, in addition to the normal household demand.

Drain Lines: All drain lines must be a **minimum of 3/4"** or equal to the size of the drain line connection at the control valve **or larger**. Avoid overhead drain lines when possible. If used, overhead drain lines are not to exceed a height of five feet above the control valve and should be no more than fifty feet in length.

Pressure Relief Valve: A pressure relief valve is installed in the aeration tank manifold and it is recommended that a separate drain line be extended toward the floor or to a drain receptacle. **NOTE:** Do not plumb to a common drain line with filter backwash discharge.

Check Valve: On applications where there is a non-filtered demand for water such as joint wells (where the filter system is only installed in one of two or more homes), outside hosebibs, farms with outbuildings, yard hydrants, etc. a spring loaded check valve is provided and must be installed ahead of the aeration tank. See Figures 1, 2 & 3 on page 8&9. It is recommended to install the check valve in a vertical upflow position with a minimum 12" water column above the check valve. This prevents air from escaping past the check valve. If the check valve is installed in a horizontal position, and there is a simultaneous demand for both non-filtered and filtered water, the air head in the aeration tank may escape backwards past the check valve into the non-filtered water line and cause air spitting.

By-Pass Valves: Always provide for a three-valve bypass on the filter system. See Figures 1, 2 & 3 on page 8&9.

Optional Filter Inlet Shut-Off: This valve allows for servicing of the filter tank and/or filter control valve without draining the aeration tank. See Figures 1, 2 & 3 on page 8&9.

Filtered Water: Normally, filtered water is furnished to all household lines; however, outside faucets are typically left on raw water. If filtered water is provided to outside faucets, the filter system must be sized accordingly.

Caution: The water pressure is not to exceed 70 p.s.i.; water temperature is not to exceed 110° F; conditioner cannot be subject to freezing conditions; conditioner cannot be subject to a negative pressure or vacuum. On installations where there is the possibility of a negative pressure or vacuum, a vacuum breaker or check valve must be installed at the inlet of the conditioner. For example, if the water service is interrupted due to a water pipe break, well pump being serviced, etc., a back siphon could occur causing a vacuum or negative pressure on the filtration equipment.

Installation Instructions

(See Page 3 for Special Factory Connections Assembly)

1. Follow all local and state plumbing and electrical codes.
2. A jumper ground wire should be installed where the metallic continuity of a water distribution piping system is interrupted.
3. Turn the water supply off.
4. If you have a water softener, place the water softener on bypass and close the shut-off valve to the water heater.
5. Drain down the plumbing system.
6. Mount the control valve and aeration pump on the filter tank.
7. Do all necessary plumbing as shown in Figures 1, 2 & 3 on page 8. If you want to filter outside hosebibs, be sure the filter system is properly sized to handle the flow rates required for extended periods of time, in addition to the normal household demand. Use a PVC compatible thread sealer when connecting fittings to the aeration tank manifold. **Care must be taken not to overtighten fittings into aeration tank manifold.**
8. Run the drain line from the filter control in accordance with local plumbing codes. **The drain line will emit surges of excess air from the aeration tank and therefore must be secured.** Models IC-10 & IC-10A have a 1/2" Male NPT Drain Connection. Models IC-12 & IC-12A have a 3/4" Female NPT Drain Connection. **For all models, use a minimum 3/4" I.D. Drain Line.**
9. Connect the 3/8" white polytubing from the white fitting on the aeration tank manifold to the air recharge valve on the Iron Curtain Control Center. Connect the 3/8" black polytubing from the black fitting on the aeration tank manifold to the air bleedoff valve on the Iron Curtain Control Center. The 3/8" white and black tubing are located in the Control Center box. **Cut tubing off to minimal necessary length after aeration tank and filter tank are in place. Secure tubing to the plumbing with cable ties provided.** Connect drain discharge line to pressure relief valve.

Start-Up

NOTE: The control valve is shipped in the air bleed off position, see step #3 in flow diagrams, page 20.

1. Close all valves that were previously opened to drain the plumbing system. Close the inlet and outlet valves on the Iron Curtain Filter System and open the filter system bypass valve. If you have a water softener, leave it on bypass also.
2. Turn on the main water supply valve and flush the water distribution system. Run water at the nearest cold water faucet until all the air is relieved, lines are flushed and the water is clear.
3. Open the inlet valve to the filter no more than 1/4 turn and allow excess air in the filter tank to escape to drain. After a steady stream of water is seen at the drain without any air, proceed to the next step.
4. Close the bypass valve and open the inlet valve all the way. Leave the outlet valve closed.

5. Plug in the electrical cord from the Iron Curtain Control Center. In approximately four minutes, the aeration pump will automatically turn on and begin to pump air into the aeration tank. Allow the Iron Curtain Control Center to finish the remaining cycles automatically (approximately 25 minutes). **Make certain that the filter control is in the Service Position** (piston all the way out). **Do NOT backwash filter at this time.** Set time of day. Time of regeneration is preset for 12:00 a.m. Regeneration frequency is preset for every three days. (Type A Filters are preset for every other day.) If you wish to reset any of these factory settings, see page 9.
6. **Make sure the filter will not regenerate within 24 hours of installation to allow the filter media to absorb water and not be backwashed out.**
7. Open the outlet valve on the filter, then open the nearest cold water faucet and allow the water to run until the air stops spurting and discoloration is gone. Note: It is normal for aerated water to appear effervescent.
8. If the water softener was placed on bypass, close the bypass valve and place the softener in service.
9. Open the shut off valve to the water heater.

Regeneration Frequency

Your Iron Curtain Filter System contains a special filter media mixture which allows it to filter iron longer than standard filters between backwash regenerations. However, it is our recommendation to leave factory settings as is, unless you wish to backwash more frequently. You will have to backwash more frequently if you have iron bacteria, hydrogen sulfide, and/or manganese present in your water supply. You will also have to regenerate more frequently if you notice iron bleed through before the end of the normal service run.

Specifications

Model	Filter & Aeration Tank Size	Media Cu. Ft	(1) Inlet/Outlet	Max. Service Flow GPM	(2) Backwash Rate GPM	Floor Space (WxHxD)
IC-10	10"x54"	1.5	3/4"	5.0	5.0	26"x70"x16"
IC-10A	10"x54"	1.5	3/4"	5.0	5.0	26"x70"x16"
IC-10+	10"x54"	1.5	3/4"	5.0	5.0	26"x70"x16"
IC-12	12"x52"	2.0	1"	7.0	8.0	30"x68"x18"
IC-12A	12"x52"	2.0	1"	7.0	8.0	30"x68"x18"
IC-12+	12"x52"	2.0	1"	7.0	8.0	30"x68"x18"

(1) Aeration Head and Check Valve have 1" Inlet/Outlet.

(2) Water temps above 60° F will require a higher backwash rate. Consult factory.

TYPE A IRON CURTAIN SYSTEMS (Optional)

When supply water has a pH between 6.0 and 6.9, a Type A filter system with sacrificial media is generally used. To insure top performance this media needs to be replenished periodically depending on water characteristics and usage patterns, generally every 6 to 18 months. This can be determined by testing the pH of the water at a cold filtered tap or by physically measuring the amount of freeboard (See Figure 8, page 4.) If the pH is 7.0 or greater, media does not need to be added. If the pH is below 7.0 and/or the amount of freeboard is greater than 18" for IC-10A or 17" for IC-12A (see step 5), media needs to be added. If media needs to be added contact your dealer and ask for the following:

Part Number 1-A8011

.66 cubic foot IC pH Correction Media (50 lb. bag)

Instructions for Adding IC pH Correction Media

See Figures 1, 2 & 3 on page 8..

1. Place Iron Curtain System on bypass. (Close inlet and outlet valves and open bypass valve.)
2. **Relieve pressure** by manually advancing timer to backwash position (see page 10). Unplug control valve after valve is shifted into backwash position and piston has stopped moving. **After pressure is relieved**, proceed.
- 2A. If your type "A" Iron Curtain filter is equipped with an optional "dome hole and bottom drain" proceed as follows otherwise advance to step three:
 - a. **After pressure is relieved remove** the dome plug by turning counter clockwise. Open the bottom drain and allow approximately 15 inches of water to drain out.
 - b. Measure down through the dome hole to determine media level. The media level may be as low as 1/2 of the total tank height or as high as 2/3 of the total tank height.
 - c. Add pH correction media and fill to a maximum level of 2/3 of the total tank height. Approximately 17-18 inches down from the top of the tank on an IC-12 or IC-10 respectively.
 - d. Replace the dome hole plug being cautious not to cross-thread. Check the o'ring seal to be sure it is clean from foreign debris. Hand tighten only, plus approximately 1/8 of a turn with a wrench. Be careful not to overtighten causing damage to the threads.
 - e. Proceed to step 11.
3. Remove the control valve from tank (see page 14). **Determine if plumbing is rigid and able to support the weight of the control valve assembly.**

If the plumbing is rigid and able to support the weight of the control valve assembly:

 - Remove the two adapter base screws and slide the tank away from the control valve and plumbing so it is easier to work on.

If the plumbing is unable to support the weight of the control valve assembly:

 - IC-10A: Loosen the union nuts on the inlet and outlet and disconnect plumbing. Loosen the fitting nuts on back of air recharge and air bleed-off valves and remove tubing. Loosen the fitting nut on drain line flow control housing and remove tubing. Loosen the screw holding the drain line flow control and disconnect the drain. Slide the tank unit away from the plumbing so it is easier to work on.
 - IC-12A: There must be a union installed on the inlet, outlet, and drain line of control valve to proceed. **If not, they must be installed prior to proceeding.** Loosen the union on the inlet, outlet, and drain and disconnect plumbing. Loosen the fitting nuts on back of air recharge and air bleed-off valves and remove tubing. Slide the unit away from the plumbing so it is easier to work on. Remove the two adapter base screws and remove the control valve assembly from the tank.
4. Remove the adapter base. Place the two adapter base screws back in the adapter base and thread in until they are flush with the bottom of the adapter base but not touching the top of the tank. Carefully place a pry bar

(long screwdriver, wrench, etc.) between the screws and apply pressure counterclockwise to loosen the adapter base. **Be careful not to crease or tear the o-rings in the adapter base.** Unscrew the adapter base from tank and remove. **Be careful not to pull up the distributor tube with adapter base. If distributor tube does pull up with the adapter base, consult your dealer.** At this point, it is recommended to remove some of the water from the tank. This can be done by placing a small hose inside the distributor tube and creating a siphon; or by carefully tipping the tank sideways, pouring out water only, not media.

5. From the top of the tank, measure down approximately 1/3 the overall height of the tank (18" for IC-10A, 17" for IC-12A) and mark the tank. This is the amount of free-board and the maximum fill height that should not be exceeded when adding media. **If media is at correct height and pH is below 7.0, do not add. Consult your dealer.**
6. Cover the distributor tube (use a plastic cap, or masking/duct tape) so media will not get into the distributor tube.
7. Using a funnel, add IC pH correction media until it reaches the maximum fill line.
8. Rinse the powdery fines from the funnel, covered distributor tube, and tank threads. Remove the funnel and uncover distributor tube.
9. Place the adapter base back on tank and thread into place until snug. **Be careful not to cross thread the adapter base in tank threads. You may need to "back thread" the adapter base to get it started correctly.**

Carefully place a pry bar (long screwdriver, wrench, etc.) between the screws and apply pressure clockwise until tight. **Be careful not to crease or tear the o-rings in the adapter base.** Remove the two screws from adapter base.

10. Reattach the control valve to the tank.

If the control valve was supported and connected to the plumbing, slide the tank underneath the control valve and align. **Be careful not to dislodge or cut o-rings.** Install the two adapter base screws and tighten.

If the control valve was disconnected from plumbing, place control valve on adapter base and align. **Be careful not to dislodge or cut o-rings.** Install the two adapter base screws and tighten.

 - IC-10A: Reconnect the drain and tighten the screw that holds the flow control housing. Reconnect the bleed-off tubing to flow control housing and tighten the fitting nut. Reconnect the tubing to the air recharge and air bleed-off valves and tighten fitting nuts. Reconnect inlet and outlet plumbing and tighten the union nuts on inlet and outlet.
 - IC-12A: Reconnect the tubing to the air recharge and air bleed-off valves and tighten fitting nuts. Reconnect inlet, outlet, and drain plumbing and tighten unions.
11. Slowly open the inlet valve and allow filter to fill at a slow rate. After a steady stream of water is running to drain, completely open inlet valve. Open outlet valve and close bypass valve.
12. Plug the control valve in and reset time of day (see page 9.)
13. Allow the system to finish the regeneration cycle and return to service.

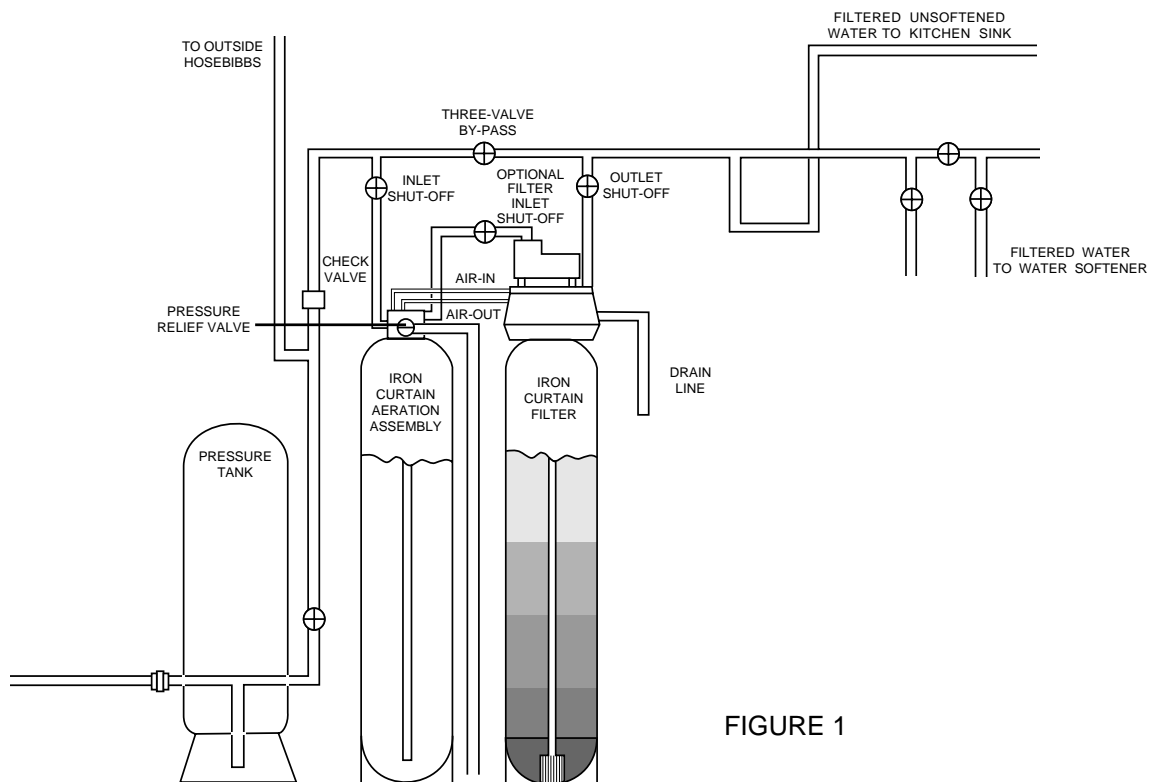

FIGURE 1

Due to existing plumbing conditions, you may want to choose an alternate installation configuration. Refer to Figures 2 and 3 below for alternate installation diagrams.

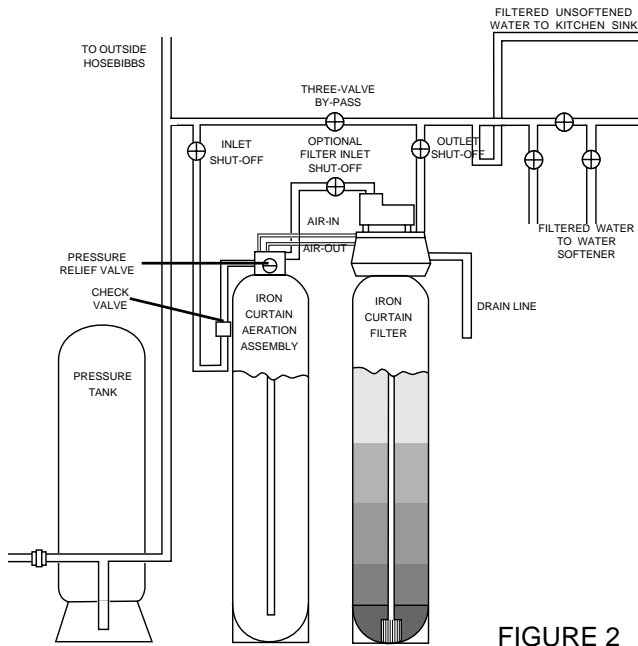

FIGURE 2

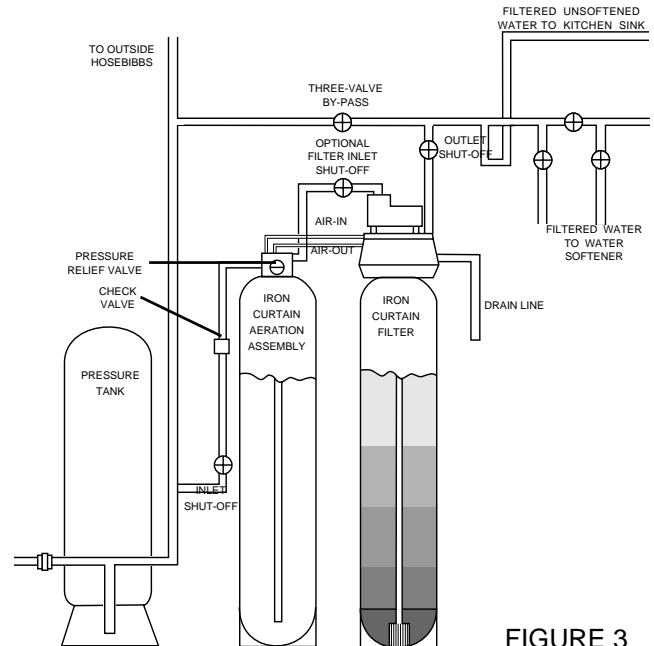

FIGURE 3

How To Set Timer

1 How to set days on which water conditioner is to regenerate.

Rotate the skipper wheel until the number "1" is at the red pointer. Set the days that regeneration is to occur by sliding tabs on the skipper wheel outward to expose trip fingers. Each tab is one day. Tab at red pointer is tonight. Moving clockwise from the red pointer, extend or retract fingers to obtain the desired regeneration schedule.

Make certain the tab aligned with red pointer is not extended outward. The filter must not regenerate within 24 hours of installation to allow the filter media to absorb water and not be backwashed out.

2 How to set the time of day.

Press and hold the red button in to disengage the drive gear.

Turn the large gear until the actual time of day is aligned with the time of day pointer.

Release the red button to again engage the drive gear.

The Iron Curtain is preset to regenerate at 12:00 a.m. provided the time of day is correct.

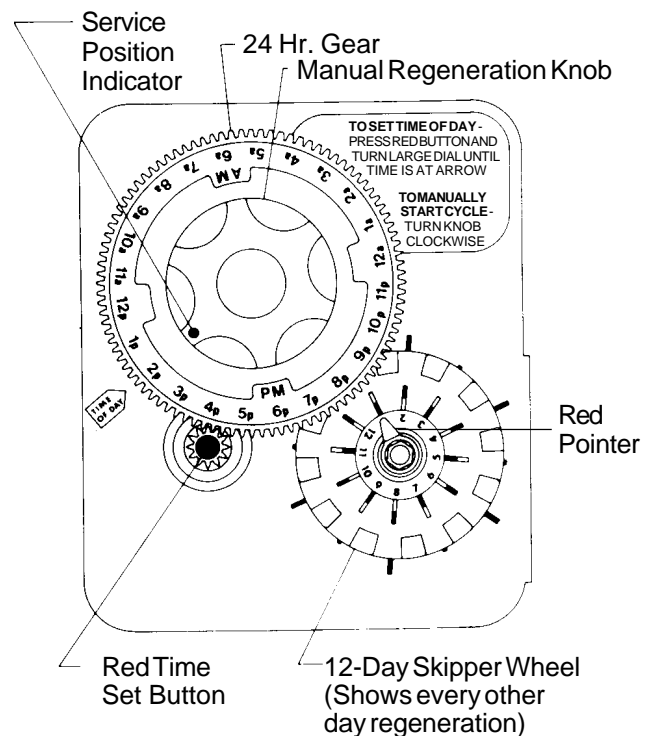

FIGURE 4

How to set Regeneration Time

The 24 hour dial of the 3200 Timer has been redesigned so that the regeneration time can be field adjusted.

To adjust follow these easy steps.

1. Disconnect the power source
2. Locate the three screws behind the manual regeneration knob by pushing the red button in and rotating the 24 hour dial until each screw appears in the cut out portion of the manual regeneration knob. (Figure B)
3. Loosen each screw slightly to release the pressure on the time plate from the 24 hour gear.
4. Locate the regeneration time pointer on the inside of the 24 hour dial in the cut out. (Figure A)
5. Turn the time plate so the desired regeneration time aligns next to the raised arrow. (Figure A)
6. Push the red button in and rotate the 24 hour dial. Tighten each of the three screws.
7. Push the red button and locate the pointer one more time to ensure the desired regeneration time is correct.
8. Reset the time of day and restore power to the unit.

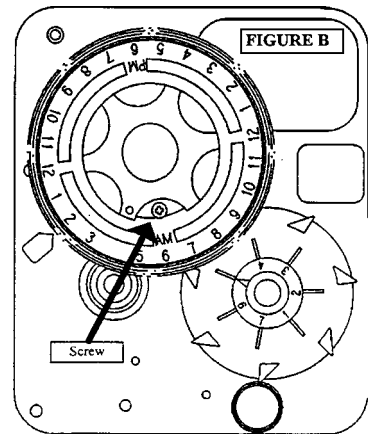
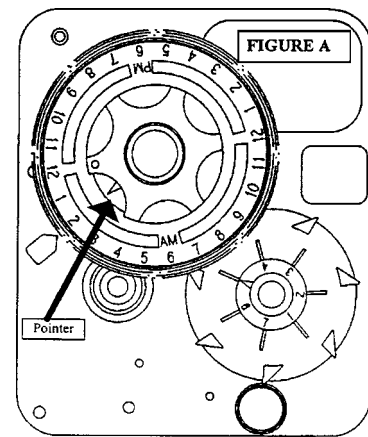

How To Manually Regenerate Your Water Filter At Any Time

Slowly turn the manual regeneration knob clockwise until the drive motor starts running.

The movement of the manual regeneration knob engages the program wheel and starts the regeneration program.

The black center knob will make one revolution in approximately the following three hours and stop in the service position as shown in the drawing.

Even though it takes three hours for this center knob to complete one revolution, the regeneration cycle of your unit is generally set for only one third of this time.

In any event, conditioned water may be drawn after rinse water stops flowing from the water conditioner drain line.

How To Manually Advance Control Center to a Specific Cycle

(See Figure 5 on page 11 for location of specific cycles.)

To manually advance the Iron Curtain Control Center to a specific cycle, you must start with unit in the service position (service position indicator aligned with time of day arrow as shown in Figure 4, Page 9). Advance the timer from one cycle to the next, pausing between each cycle until the drive motor stops running. If you do not wait until the drive motor stops

running, the timer and the drive motor will become out of synch. If that happens, advance the timer to the service position and the control valve piston will return also to the service position. They are now resynchronized.

The first cycle is the *backwash* cycle: Slowly turn manual regeneration knob clockwise until backwash pins engage microswitch arm and drive motor begins running. Wait until drive motor stops before proceeding to next cycle.

The second cycle is the *air recharge* cycle: Slowly turn the manual regeneration knob clockwise until backwash pins drop off microswitch arm and drive motor begins running. Wait until drive motor stops before proceeding to next cycle.

The third cycle is the *rapid rinse* cycle: Slowly turn the manual regeneration knob clockwise until rapid rinse pins engage microswitch arm and drive motor begins running. Wait until drive motor stops before proceeding to next cycle.

The fourth cycle is the *cycle advance* cycle: Slowly turn the manual regeneration knob clockwise until rapid rinse pins drop off microswitch arm and drive motor begins running. Wait until drive motor stops before proceeding to next cycle.

The final cycle is the *cycle shut off* cycle: Slowly turn the manual regeneration knob clockwise until cycle shut off pins engage microswitch arm and drive motor begins running. Wait until drive motor stops before advancing the timer to service position.

How To Set Regeneration Cycle Program

(Refer to page 3 for factory settings)

1 How to set the regeneration cycle program.

The regeneration cycle program on your Iron Curtain Filter has been factory preset, however, portions of the cycle or program may be lengthened or shortened to suit local conditions.

To expose cycle program wheel, grasp timer in upper left-hand corner and pull, releasing snap retainer, and swing timer to the right.

To change the regeneration cycle program, the program wheel must be removed. Make sure the timer is in the service position and then unplug the power cord. Grasp program wheel and squeeze protruding lugs toward center of wheel. Lift program wheel off timer. (The arm on the program actuator switch may need to be moved to facilitate removal.)

After making the necessary adjustments described in steps 2, 3, and 4, install the program wheel on the timer. Place program wheel over the protruding lugs and gently push program wheel on until the tabs on the lugs are snapped in place over the wheel. (The arm on the program actuator switch may need to be moved to facilitate installation.)

Return timer to closed position engaging snap retainer in back plate. Make certain all electrical wires are located above snap retainer post. Plug in power cord.

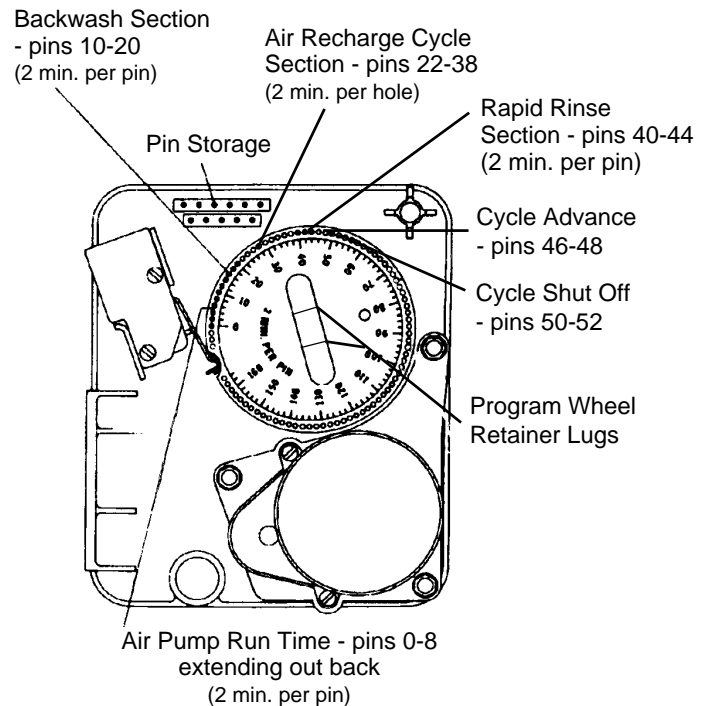

FIGURE 5

2 How to change the length of the backwash time.

The program wheel as shown in the drawing is in the service position. As you look at the numbered side of the program wheel, the group of pins starting at 10 determines the length of time that your Iron Curtain Filter will backwash.

For example: If there are six pins in this section, the time of the backwash will be 12 minutes (2 minutes per pin).

To lengthen backwash time, remove 1" long roll pin(s) from pin storage on timer (1 pin needed for each 2 minutes to be added). Beginning at number 10 and counting up, remove pin(s) (1 pin for each long roll pin to be added to extend air recharge time). Replace with long roll pin(s) so it extends out back equal distance with existing pins. For each long roll pin added, move the rapid rinse pin to the higher numbered end of wheel. IMPORTANT: After installing long roll pin(s), turn the manual regeneration knob clockwise one revolution to make sure long roll pin(s) do not touch drive gear (Item 22, Figure 7, page 13).

3 How to change the length of air recharge cycle (ARC).

The group of holes between the last pin in the backwash section and the second group of pins determines the length of time that your Iron Curtain Filter is in the air recharge cycle rinse (2 minutes per hole). **Note: This cycle also uses the set of pins on the backside of the program wheel simultaneously with the first set of spaces on the front side of the program wheel.**

To lengthen the air recharge time, remove 1" long roll pin(s) from pin storage on timer (1 pin needed for each 2 minutes to be added). Beginning at number 10 and counting up, remove pin(s) (1 pin for each long roll pin to be added to extend air recharge time). Replace with long roll pin(s) so it extends out back equal distance with existing pins. For each long roll pin added, move the rapid rinse pin to the higher numbered end of wheel.

After the rapid rinse pins, leave two holes then place two pins. IMPORTANT: After installing long roll pin(s), turn the manual regeneration knob clockwise one revolution to make sure long roll pin(s) do not touch drive gear (Item 22, Figure 7, page 13).

4 How to change the length of rapid rinse time.

The second group of pins on the number side of the program wheel determines the length of time that your Iron Curtain Filter will rapid rinse (2 minutes per pin). To lengthen the rapid rinse time, add pins at the higher numbered end of this section as required. After the rapid rinse pins, leave two holes then place two pins.

The regeneration cycle is complete when the program actuator microswitch drops off the last pin. The program wheel however, will continue to rotate until the homing microswitch drops into the notch on the program wheel.

Iron Curtain System

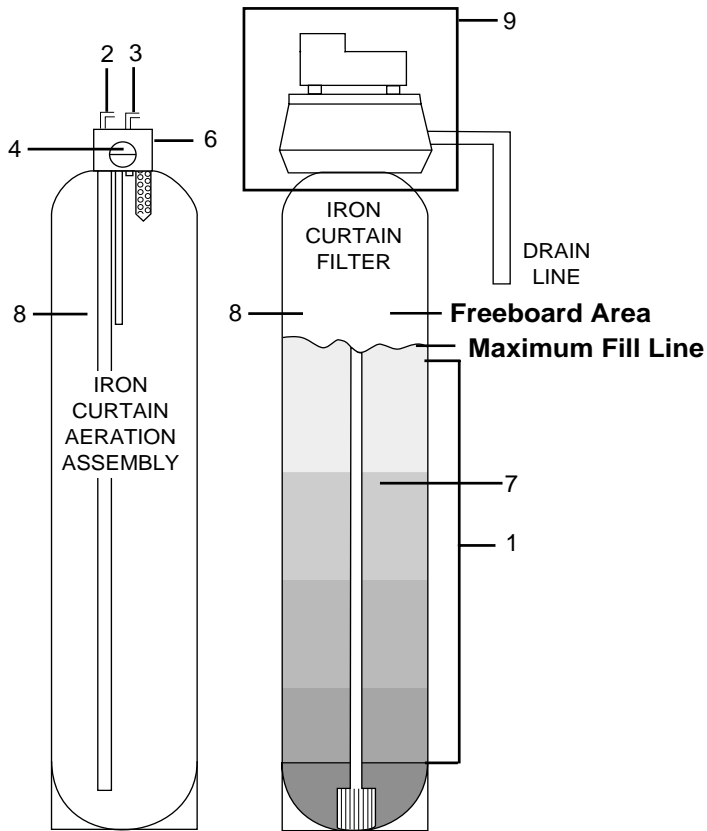

FIGURE 8

ITEM NO.	NO. REQ'D.	PART NO.	DESCRIPTION
1	1	1-010	IC-10 Rebed Mix
		1-010A	IC-10A Rebed Mix
		1-010+	IC-10+ Rebed Mix
		1-012	IC-12 Rebed Mix
		1-012A	IC-12A Rebed Mix
		1-012+	IC-12+ Rebed Mix
			Consult factory for larger systems
2	1	11-P6ME4	3/8" Tube x 1/4" Male Elbow (Black - Air Bleedoff Fitting)
3	1	22-20	3/8" Tube x 1/4" Male Elbow (White - Air Recharge Fitting)
4	1	22-22	1/2" Relief Valve
5	1	22-15	1" Check Valve (not shown)
6	1	22-36	1" Aeration Head Assembly for the IC-10 and IC-10A
		22-36-12	1" Aeration Head Assembly for the IC-12 and IC-12A
			Includes: Machined Aeration Head, Inlet Diffuser, Pick-up Tube, Bleedoff Tube, 1/2" Relief Valve, 1" Check Valve, Air Recharge Fitting, Air Bleedoff Fitting, Misc. Labels
7	1	9-93154	1.050x54" Distributor Assy.-IC-10
		9-93152	1.050x52" Distributor Assy.-IC-12
8	1	19-PG1054BG	10"x54" Polyglass Tank - IC-10
		19-PG1252BG	12"x52" Polyglass Tank - IC-12
9	1	22-43	IC-10 Valve & Pump Assy Complete
		22-47	IC-12 Valve & Pump Assy Complete

Iron Curtain Wiring Diagram

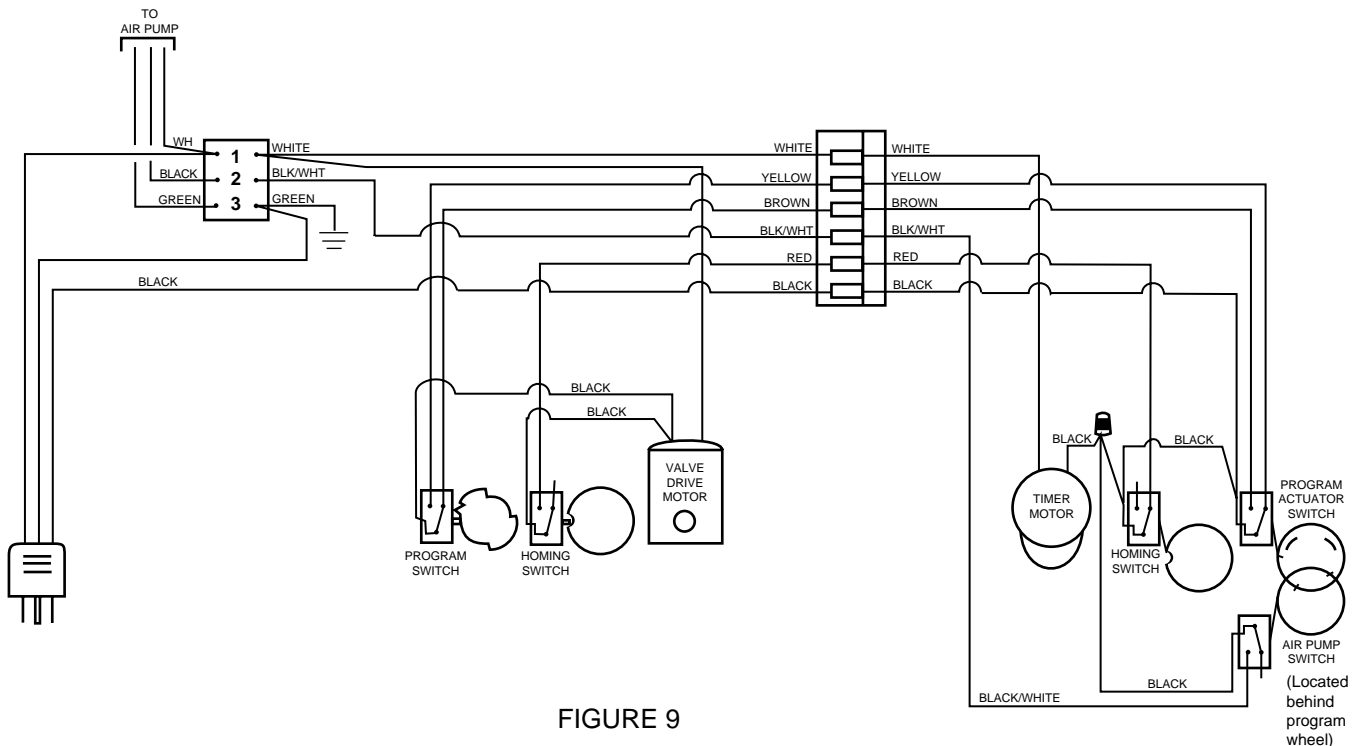

FIGURE 9

Iron Curtain Timer Assembly

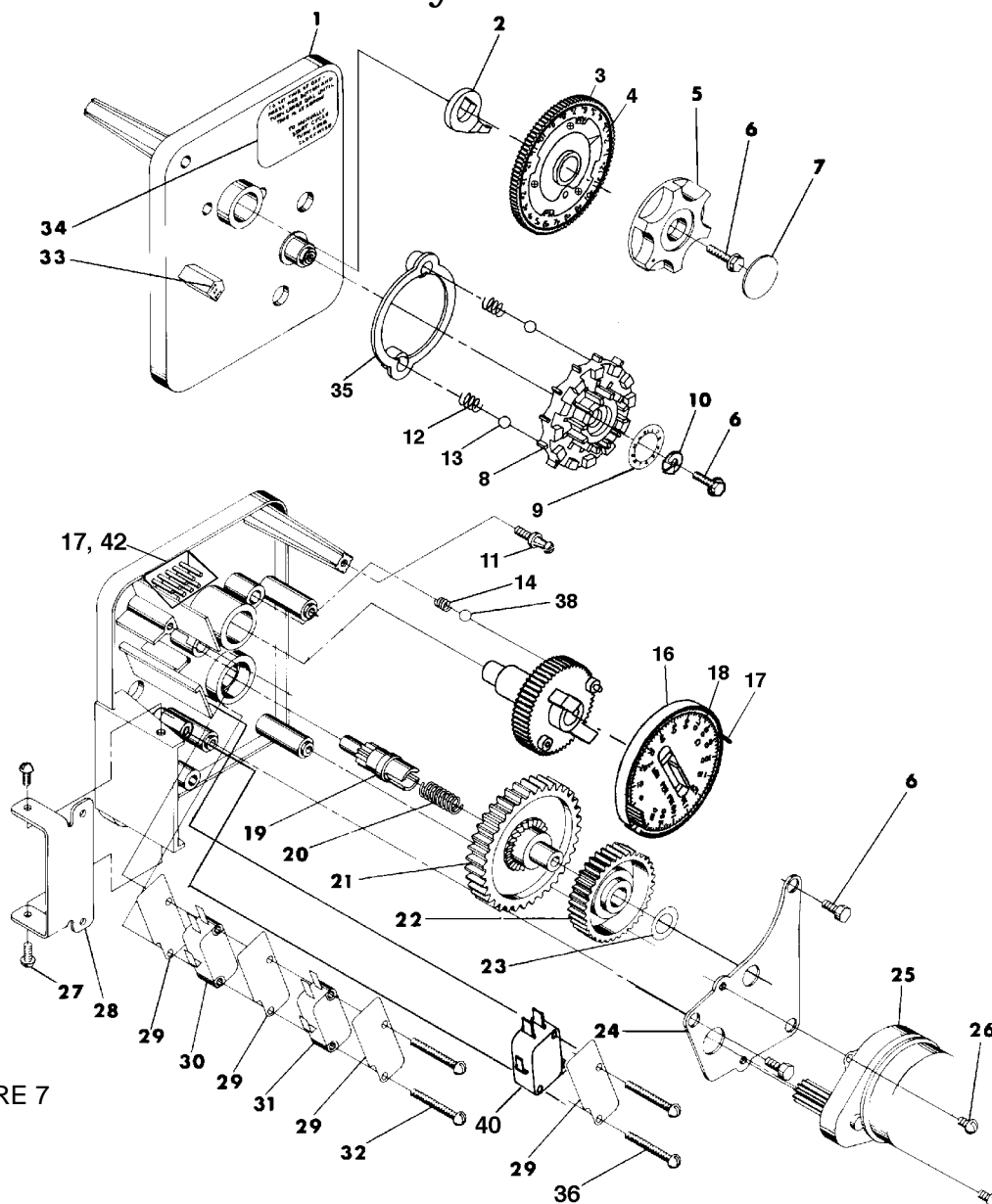

FIGURE 7

ITEM NO.	NO. REQ'D.	PART NO.	DESCRIPTION	ITEM NO.	NO. REQ'D.	PART NO.	DESCRIPTION
1	1	49-13870	Timer Housing	22	1	49-15275	Drive Gear
2	1	49-13011	Cycle Actuator Arm	23	1	49-13299	Curved Washer
3	1	49-49-60519	24 Hour Gear	24	1	49-13887	Motor Mounting Plate
4	1	49-13959	24 Hour Label - Silver	25	1	49-13944	Motor - 110V., 60 Hz.
5	1	49-13886	Knob			49-14104	Motor - 24V., 60 Hz.
6	5	49-13296	Screw - Timer Knob & Motor Mtg. Plate	26	2	49-13278	Screw - Motor Mounting
7	1	49-11999	Button Decal	27	3	49-11384	Screw - Timer Hinge & Ground -Wire
8	1	49-14381	Skipper Wheel Assembly - 12 Day	28	1	49-13881	Hinge Bracket
9	1	49-13429	Skipper Wheel Label - 12 Day	29	4	49-14087	Insulator
10	1	49-13014	Regeneration Pointer	30	1	49-10896	Homing Switch
11	1	49-14265	Spring Clip	31	1	49-15320	Program Actuator Switch
12	2	49-13311	Spring - Skipper Wheel Detent	32	2	49-11413	Screw - Switch Mounting
13	2	49-13300	Ball - 1/4" Dia. Skipper Wheel	33	1	49-14007	Decal - Time of Day
14	1	49-14457	Spring - Main Gear Detent	34	1	49-14045	Decal - Instructions
15	1	49-13911	Main Drive Gear	35	1	49-13864	Skipper Wheel Ring
16	1	49-13880	Program Wheel	36	2	49-11805	Single Micro Switch Screw
17	11	49-15493	Roll Pin	37	2	49-12681	Wire Connector (not shown)
18	1	49-13901	Program Wheel Decal	38	1	49-15066	Ball 1/4" Dia. Main Gear
19	1	49-13018	Idler Shaft	39	1	49-15354-01	Ground Wire (not shown)
20	1	49-13312	Spring - Idler	40	1	49-15320	Air Pump Switch
21	1	49-13017	Idler Gear	41	5	49-15808	Roll Pin - Air Pump Switch (not shown)
				42	0	49-12625	1" Long Roll Pin

Iron Curtain Control Drive Assembly

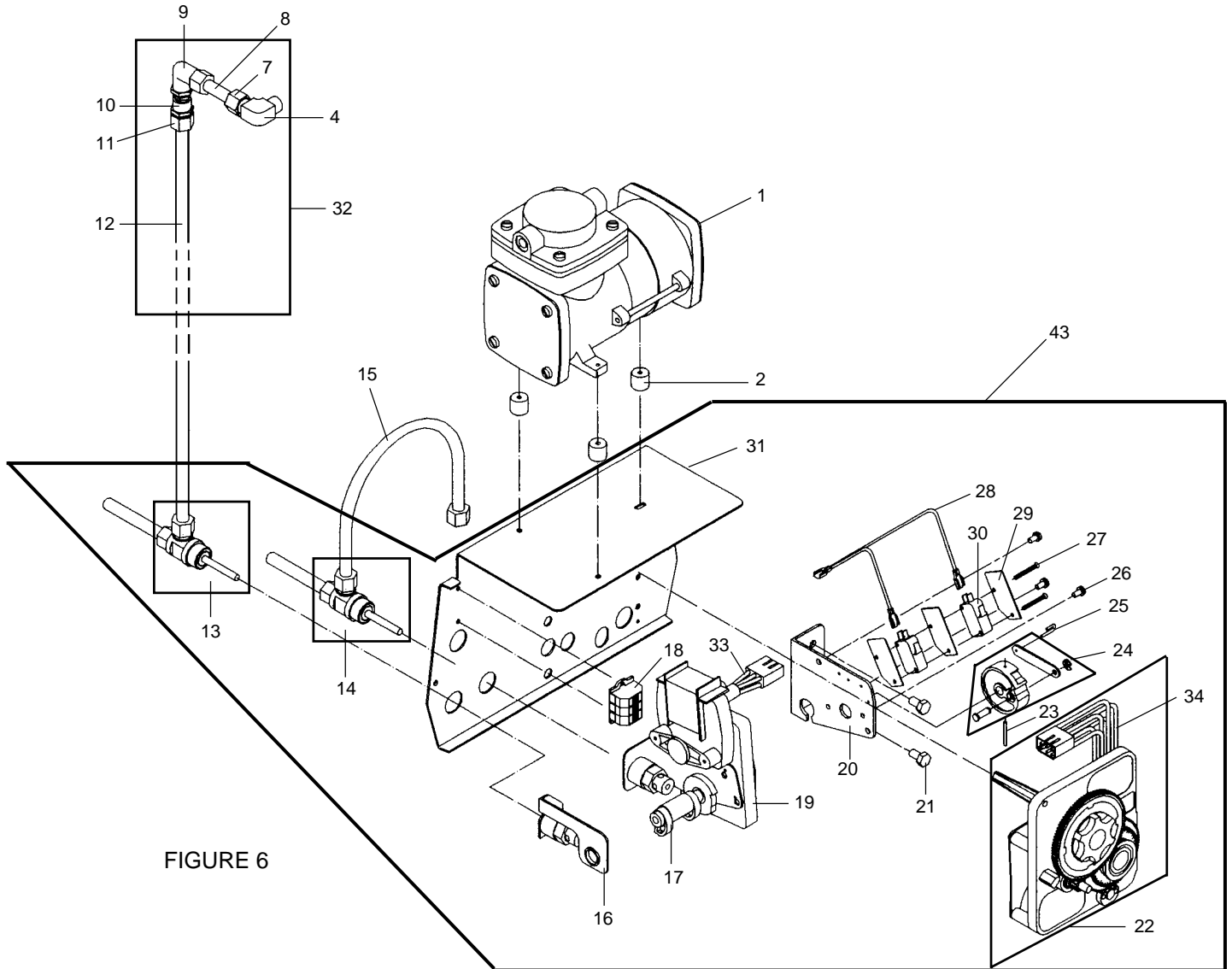

FIGURE 6

ITEM NO.	NO. REQ'D.	PART NO.	DESCRIPTION	ITEM NO.	NO. REQ'D.	PART NO.	DESCRIPTION
1	1	22-01	IC Air Pump	22	1	49-60304-IC	IC Timer Assy. w/Air Pump Switch
2	3	22-05	IC Pump Feet	23	1	49-10338	Roll Pin
3	3	22-06	IC Pump Feet Nut (not shown)	24	1	49-60160-10	Drive Cam Assembly
4	1	22-03	3/8" Brass Elbow	25	1	49-10909	Connecting Link Pin
5	1	49-10330	3/8" Delrin Sleeve (not shown) (inside brass nut and elbow)	26	5	49-10872	Screw – Motor Mounting
6	1	49-10332	3/8" Tube Insert (not shown) (inside brass nut and elbow)	27	2	49-14923	Screw – Switch Mounting
7	1	22-03N	3/8" Brass Nut	28	1	49-11752	Motor Lead Wires
8	1	49-13147	3/8" x 1' PVC Tubing (2-1/4" Piece Needed)	29	3	49-10302	Insulator
9	1	22-19	3/8" Tube x 1/4" FPT White Elbow	30	2	49-10218	Micro Switch
10	1	22-961	1/4" MPT Stainless Steel Check Valve	31	1	49-16562	IC Backplate
11	1	22-18	3/8" Tube x 1/4" FPT White Connector	32	1	22-381-1	IC Check Valve Replacement Kit
12	1	2-P5-38N	3/8" x 500' Natural Tubing (8" piece needed)	33	1	49-18299	IC Wire Harness – Drive
13*	1	22-54	IC Air Recharge Plastic Valve	34	1	49-17138	IC Wire Harness – Timer
14*	1	22-55	IC Air Bleedoff Plastic Valve	35	2	49-13296	Screw–Terminal Block (not shown)
15	1	2-P5-38	3/8" x 500' Black Tubing (9-1/2" piece needed)	36			Not Used
16	1	49-12114	IC Recharge/Bleed-off Cam Bracket	37	1	49-60232	Designer Cover (not shown)
17	1	49-16637	IC Recharge/Bleed-off Cam	38	2	49-15742	Designer Cover Screw (not shown)
18	1	49-15226-3	Terminal Strip	39	2	49-15833	Spacer – Designer Cover Screw (not shown)
19	1	49-10769	Drive Motor	40	2	49-10250	Retaining Ring – Designer Cover Screw (not shown)
20	1	49-10774	Bracket - Motor Mounting	41	1	72-A1008	Iron Curtain Cover Label (not shown)
21	2	49-10231	Screw - Drive Mounting	42	1		Model No. Label (not shown)
				43	1	49-60407-61	IC Powerhead Assembly
				44	1	49-11838	IC Power Cord (not shown)
				45	2	49-14932	Speed Nut for Cover Screw (not shown)

14 *To replace brass IC Air Recharge and Air Bleedoff valves on systems manufactured prior to October 1997, order p/n 22-56 IC Plastic Air Recharge/Bleedoff Retrofit Kit which includes both valves and machined cover to accommodate the larger plastic valve holding nuts.

Iron Curtain Aeration Pump

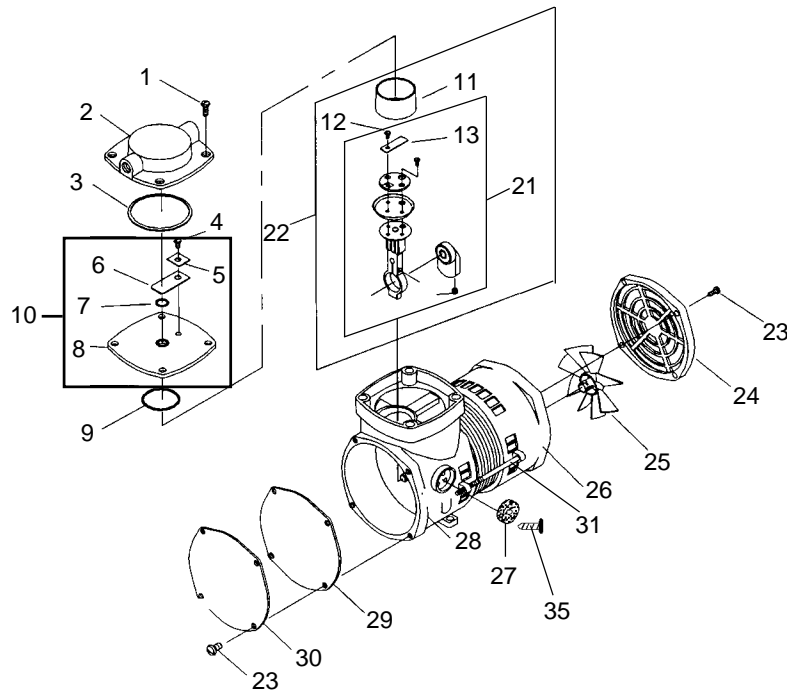

FIGURE 10

Item No.	Part No.	Description	Qty.	Item No.	Part No.	Description	Qty.
1	74-625646	Screw/Head	4	21	74-607604	Connecting Rod Assy	1
2	74-660631-504	Head	1	22	74-607605	Connecting Rod, Valve Plate Eccentric & Set Screw Assy	1
3	74-623121	O-Ring/Head	1	23	74-625449	Screw/Cover	8
4	74-625307	Screw-Exhaust Valve Flapper	1	24	74-614609	Cover/Fan	1
5	74-617045	Valve Keep Strip	1	25	74-633504	Fan	1
6	74-621102	Exhaust Valve Flapper	1	26	74-614425-504	Motor End Cap	1
7	74-623615	O-Ring/Valve Flapper	1	27	74-641169	Air Filter	1
8	74-662150	Valve Plate	1	28	74-669213-504	Housing	1
9	74-623537	O'Ring/Piston Sleeve	1	29	74-633562	Gasket/Front Cover	1
10	74-662784	Valve Plate Assembly	1	30	74-614430	Front Cover	1
11	74-618145	Piston Sleeve	1	31	74-625107	Screw/Slator	2
12	74-625160	Screw/Ramped Intake Valve Flapper	1	32	22-01	IC Complete Air Compressor	1
13	74-621488	Intake Valve Flapper	1	33	74-650465	405 Air Pump Service Kit (Not Shown) (Includes # 3,4,5,6,7,9,11,12,29)	1
				34	74-650571	405 Air Pump Rebuild Kit (Not Shown) (Includes 22, 33)	1

Iron Curtain Aeration Pump Repair Instructions

Air pump must be removed from tank and have power supply disconnected before proceeding.

1. Remove four front cover screws and remove front cover and cover gasket.
2. Remove four pump head screws and remove pump head.
3. Remove valve plate assembly.
4. Remove felt air filter on side of pump with a flat screw driver prying under the flat center retainer.
5. Remove piston sleeve from connecting rod assembly.
6. Using an 1/8" allen wrench through the air intake hole loosen eccentric/bearing and piston connecting rod assembly set screw and remove eccentric/bearing and connecting rod assembly.
7. If eccentric & bearing assembly need replacing: Using a 1/8 allen wrench through air intake hole, loosen eccentric & bearing assembly screw and remove eccentric & bearing assembly. Remove piston sleeve from connecting rod assembly. Remove valve flapper screw and valve flapper. Remove intake valve plate screws and remove ramped valve plate and piston cup. Install new piston cup on connecting rod. Place a dab of silicone caulk in the center dimple on bottom side of ramped valve plate and install ramped valve plate and intake valve plate screws (12" lbs.) making sure the intake hole is aligned in the connecting rod, piston cup and ramped valve plate. Install new valve flapper and valve screw (12" lbs.). Slide new piston sleeve upwards over connecting rod assembly starting from the bottom, forcing new piston cup to curve upwards inside piston sleeve. Note: If piston sleeve slides over the top of connecting rod assembly, reinstall, starting from the bottom.
8. If installing new connecting rod assembly, slide new piston sleeve upwards over connecting rod assembly starting from the bottom, forcing new piston cup to curve upwards inside piston sleeve. Note: If piston sleeve slides over top of connecting rod assembly, reinstall, starting from the bottom.
9. From the top of the pump insert connecting rod/eccentric bearing assembly with set screw facing air filter holes. Install on motor shaft all the way and tighten set screw (8" lbs.) **Note: Set screw should tighten onto flat spot on motor shaft.**
10. Remove exhaust valve flapper screw, valve keeper strip, valve flapper, valve flapper o-ring and piston sleeve o-ring from valve plate. Lubricate new o-rings with silicone lubricant to hold o-rings in place and install in valve plate. Install new valve flapper, valve keeper strip and exhaust valve flapper screw (12" lbs.) in valve plate.
11. Install valve plate on pump, aligning piston sleeve o-ring with top of piston sleeve.
12. Remove o-ring from pump head. Place 3-4 small dabs of silicone lubricant in pump head o-ring groove to hold o-ring in place and install o-ring in pump head.
13. Install pump head on pump, aligning exhaust port with front of pump. Install four pump head screws and tighten (48" lbs.).
14. Remove any remaining gasket material from front cover and pump front and make sure both surfaces are clean.
15. Install new front cover gasket with burr side in. Install front cover and four cover screws and tighten screws (20" lbs.).
16. Air pumps manufactured after 11/94 use an air filter with a hole in the center and a plastic press in retainer to hold it in place. To replace air filter, order p/n 74-641169 Air Filter and Retainer. Place air filter in place and install new retainer.

IC-10 Series Control Valve Assembly

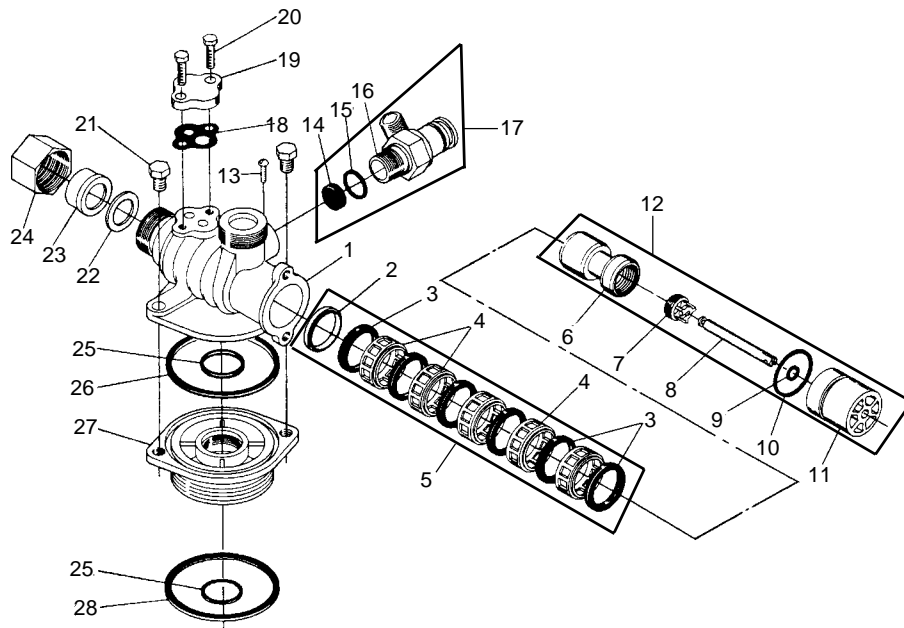

FIGURE 11

ITEM NO.	NO. REQ'D.	PART NO.	DESCRIPTION
1	1	49-11212NP	Nickel Valve Body
2	1	49-10757	End Spacer
3	6	49-10545	Seal Ring
4	5	49-11451	Spacer
5	1	49-60121	Seal/Spacer Kit
6	1	49-15168	Piston
7	1	49-14309	Piston Rod Retainer
8	1	49-14452	Piston Rod
9	1	49-10209	Seal Quad Ring
10	1	49-10234	End Plug O-Ring
11	1	49-10598	End Plug
12	1	49-60090	2500 Piston Assembly
13	1	49-11180	Flow Control Retainer Screw
14	1	49-12092	5.0 gpm DLFC Button
15	1	49-11183	DLFC Fitting O-Ring
16	1	49-12619	2500 SVO Drain Fitting
17	1	49-12619-5	IC-10 5 gpm DLFC Assembly
18	1	49-11475	Injector Body Gasket
19	1	49-11893	Flat Cap
20	2	49-15137	Flat Cap Screw
21	2	49-11224	Adapter Base Screw
22	2	49-11206	Inlet/Outlet Fitting Gasket
23	2	49-11205	Inlet/Outlet Tube Fitting
24	2	49-11207NP	Inlet/Outlet Nickel Nut
25	2	49-11710	Inside Tube O-Ring
26	1	49-11208	Adapter Base Seal O-Ring
27	1	49-12461NP	Nickel Adapter Base
28	1	49-10381	Adapter Base Tank O-Ring

SERVICE TOOLS needed for removing and replacing piston seals and spacers for both IC-10 & IC-12.

49-13061	Spacer Puller
49-PICK	O'Ring and Seal Pick
49-11098	Spacer Stuffer

IC-12 Series Control Valve Assembly

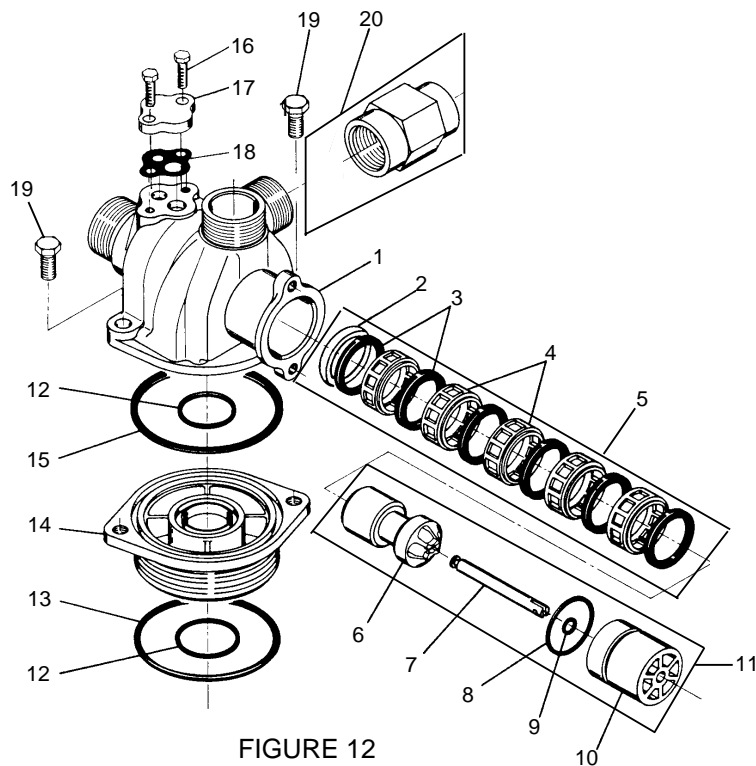

FIGURE 12

ITEM NO.	NO. REQ'D.	PART NO.	DESCRIPTION
1	1	49-14749-02NP	Nickel Valve Body
2	1	49-10757	End Spacer
3	6	49-10545	Seal Ring
4	5	49-11451	Spacer
5	1	49-60121	Seal/Spacer Kit
6	1	49-11451	Piston
7	1	49-14452	Piston Rod
8	1	49-10234	End Plug O-Ring
9	1	49-10209	Seal Quad Ring
10	1	49-10598	End Plug
11	1	49-60090-HF	2750 Piston Assembly
12	2	49-11710	Inside Tube O-Ring
13	1	49-10381	Adapter Base Tank O-Ring
14	1	49-12461NP	Nickel Adapter Base
15	1	49-11208	Adapter Base Seal O-Ring
16	2	49-15137	Flat Cap Screw
17	1	49-11893	Flat Cap
18	1	49-11475	Injector Body Gasket
19	2	49-11224	Adapter Base Screw
20	1	49-60700-8.0	IC-12 8 gpm DLFC Assembly

SERVICE TOOLS needed for removing and replacing piston seals and spacers for both IC-10 & IC-12.

49-13061	Spacer Puller
49-PICK	O'Ring and Seal Pick
49-11098	Spacer Stuffer

Instructions for Replacing Piston Assembly and Seal Kit

Replacing Piston Assembly

See pages 17 and 18 for Parts Diagrams.

1. Place Iron Curtain System on bypass. (Close inlet and outlet valves and open bypass valve.) See Figures 1, 2 & 3 on page 8.
2. Relieve pressure by manually advancing timer to backwash position (See page 10). Unplug control valve after valve is shifted into backwash position (piston all the way in) and piston has stopped moving. After pressure is relieved, proceed.
3. With a 5/8" wrench
 - Loosen fitting nuts on back of air recharge valve and air bleedoff valves (3/8" white and black polytubing connecting the control valve to aeration head) and disconnect tubings from air recharge and air bleedoff valves.
 - Loosen remaining fitting nut on air bleedoff valve and disconnect tubing. (3/8" black polytubing connecting air bleedoff valve to drain fitting.)
4. While holding the powerhead assembly firmly, remove the two capscrews holding powerhead backplate to valve body and remove the powerhead and piston assemblies. Note: Some piston seals and/or spacers may come out of the valve body with the piston assembly. If so, see Seal Kit Replacement instructions for re-installing them.
5. Remove connecting link pin that connects piston rod to the connecting link on drive cam assembly and remove piston assembly.
6. Inspect the inside of the valve to make sure that all piston seals and spacers are in place. If piston seals and/or spacers need to be re-installed or replaced, see Seal Kit Replacement instructions.
7. Lubricate the piston and piston seals with silicone lubricant.
8. Start the piston into the valve body and slowly push the piston assembly with end plug into the valve body. Push piston rod in all the way, leaving only the connecting hole end without teflon coating exposed.
9. Place two capscrews through holes in backplate, align with female threads in valve body and turn capscrews a couple turns to support powerhead assembly. Do not completely tighten screws until connecting link pin is installed. Caution: Be careful not to scratch exposed piston rod.
10. Install connecting link pin, connecting piston rod to the connecting link on drive cam. Note: If connecting link pin hole and piston rod hole are not aligned, the drive motor can be disengaged by grasping the motor shaft on the upper left side of drive motor and pulling outwards. While holding the motor shaft out, the drive cam can be turned clockwise to move connecting link to align connecting link hole with piston rod hole.
11. Tighten the two capscrews and plug in control valve powercord.
12. Manually advance the timer to service position and allow control valve to cycle until in the service position. See page 10 for instructions on manually advancing timer.
13. Manually advance the timer to the backwash position and allow to stop. Then advance timer to the beginning of the air recharge cycle. Unplug the control valve powercord.
14. Open inlet valve no more than 1/4 turn and allow system to fill slowly. After a steady stream of water is seen at the drain without excess air, proceed to the next step.
15. Close the bypass valve and open the inlet valve all the way.
16. Plug in the control valve powercord. In approximately four minutes, the aeration pump will automatically turn on and begin to pump air into the aeration tank. Allow the Iron Curtain Control Center to finish the remaining cycles. Set time of day.
17. Open the outlet valve on the filter, then open the nearest cold water faucet and allow the water to run until the air stops spurting and discoloration is gone. Note: It is normal for aerated water to appear effervescent.

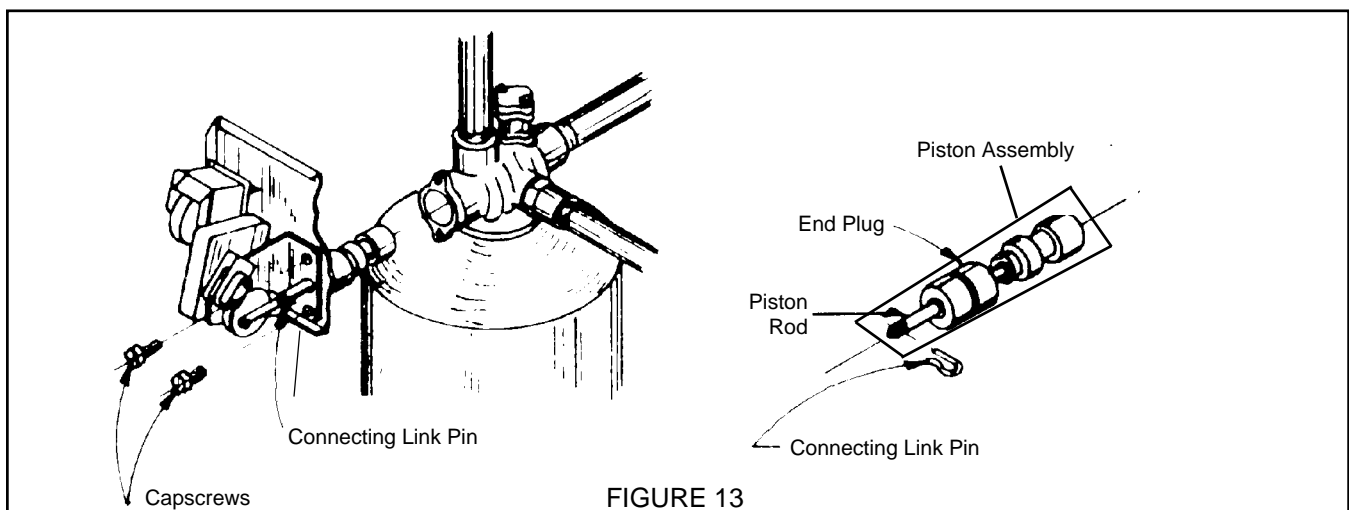
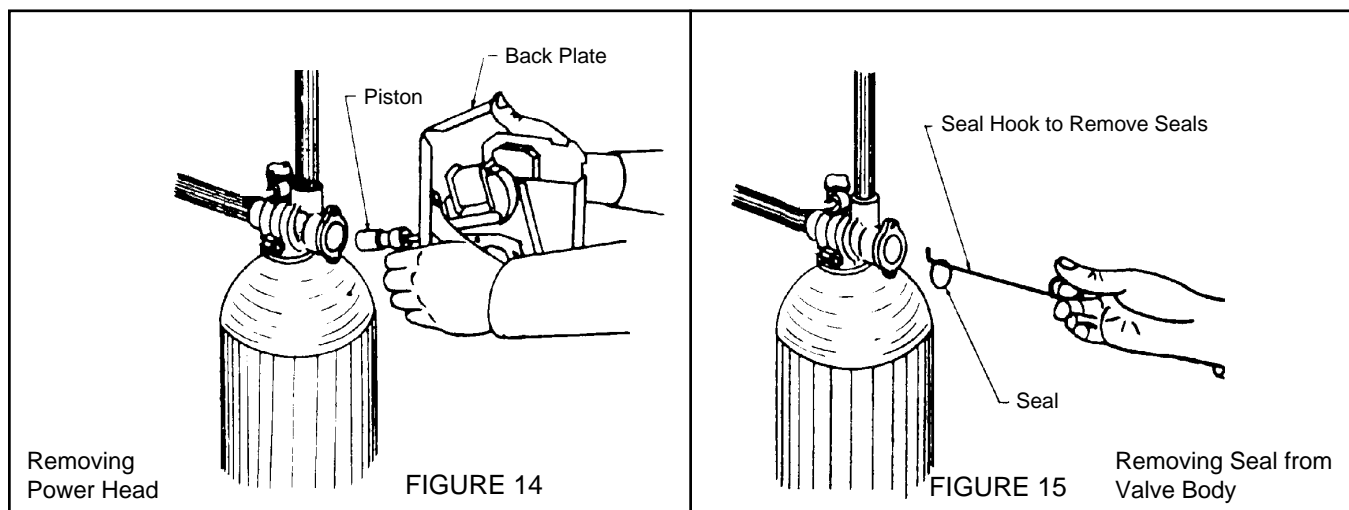

FIGURE 13

Replacing Seal Kit

1. To replace seal kit, the follow special tools are needed.
 - A. Seal Hook: Used to remove piston seals.
 - Wire hook with finger loop
 - B. Puller: Used to remove piston spacers.
 - Has 3 retractable pins retained by a rubber ring at one end. They are retracted or pushed out by pulling or pushing the center button on the opposite end.
 - C. Stuffer: Used to install rubber seals and plastic spacers.
 - Double-purpose tool with brass sleeve on one end.
2. Place Iron Curtain System on bypass. (Close inlet and outlet valves and open bypass valve.) See Figures 1, 2 & 3 on page 8.
3. Relieve pressure by manually advancing timer to backwash position (See page 10). Unplug control valve after valve is shifted into backwash position (piston all the way in) and piston has stopped moving. After pressure is relieved, proceed.
4. With a 5/8" wrench
 - Loosen fitting nuts on back of air recharge valve and air bleedoff valves (3/8" white and black polytubing connecting the control valve to aeration head) and disconnect tubings from air recharge and air bleedoff valves.
 - Loosen remaining fitting nut on air bleedoff valve and disconnect tubing. (3/8" black polytubing connecting air bleedoff valve to drain fitting.)
5. Remove the two capscrews holding powerhead backplate to valve body and remove the powerhead and piston assemblies. CAUTION: Be careful not to scratch the exposed piston rod. Note: Some piston seals and/or spacers may come out of the valve body with the piston assembly.
6. Remove connecting link pin that connects piston rod to the connecting link on drive cam assembly and remove piston assembly.
7. Using the seal hook, remove the first seal.
 8. Using the puller, remove the first spacer.
 9. Alternately remove the remaining seals and spacers in accordance with steps #7 and 8.
 10. The last or end spacer does not have any holes for the pins of the puller to engage, therefore if the end spacer does not come out on the first try, try again using the seal hook.
 11. With your thumb press the button on the brass sleeve end of the stuffer and hold. Place the end spacer on the male end of the stuffer with the lip on end spacer facing the stuffer and push the stuffer into the valve body bore until it bottoms. While the tool is in the valve body, take a piston seal and press it into the inside diameter of the exposed brass female end.
 12. Remove the tool, turn it end for end and insert it into the valve body bore until it bottoms, then push the center button to push seal out of the stuffer and leave it in place in the valve body.
 13. Remove the stuffer from the valve body, turn it end for end and push the center on the brass female end to expose the pilot on male end and hold. Place a spacer on the pilot and insert the spacer and stuffer into the valve body.
 14. While the stuffer is still in the valve, press another seal into the inside diameter of the exposed brass female end.
 15. Remove the tool, turn it end for end, and insert it into the valve body bore.
 16. Alternately repeat steps 13 through 15 until all seals and spacers have been pushed into the valve.
 17. Lubricate the piston and piston seals with silicone lubricant.
 18. Start the piston into the valve body and slowly push the piston assembly with end plug into the valve body. Push piston rod in all the way, leaving only the connecting hole end without teflon coating exposed.
 19. Place two capscrews through holes in backplate, align with female threads in valve body and turn capscrews a couple turns to support powerhead assembly. Do not completely tighten screws until connecting link pin is installed. Caution: Be careful not to scratch exposed piston rod.



20. Install connecting link pin, connecting piston rod to the connecting link on drive cam. Note: If connecting link pin hole and piston rod hole are not aligned, the drive motor can be disengaged by grasping the motor shaft on the upper left side of drive motor and pulling outwards. While holding the motor shaft out, the drive cam can be turned clockwise to move connecting link to align connecting link hole with piston rod hole.
21. Tighten the two capscrews and plug in control valve powercord.
22. Manually advance the timer to service position and allow control valve to cycle until in the service position. See page 10 for instructions on manually advancing timer.
23. Manually advance the timer to the backwash position and allow to stop. Then advance timer to the beginning of the air recharge cycle. Unplug the control valve powercord.

24. Open inlet valve no more than 1/4 turn and allow system to fill slowly. After a steady stream of water is seen at the drain without excess air, proceed to the next step.
25. Close the bypass valve and open the inlet valve all the way.
26. Plug in the control valve powercord. In approximately four minutes, the aeration pump will automatically turn on and begin to pump air into the aeration tank. Allow the Iron Curtain Control Center to finish the remaining cycles. Set time of day.
27. Open the outlet valve on the filter, then open the nearest cold water faucet and allow the water to run until the air stops spurting and discoloration is gone. Note: It is normal for aerated water to appear effervescent.

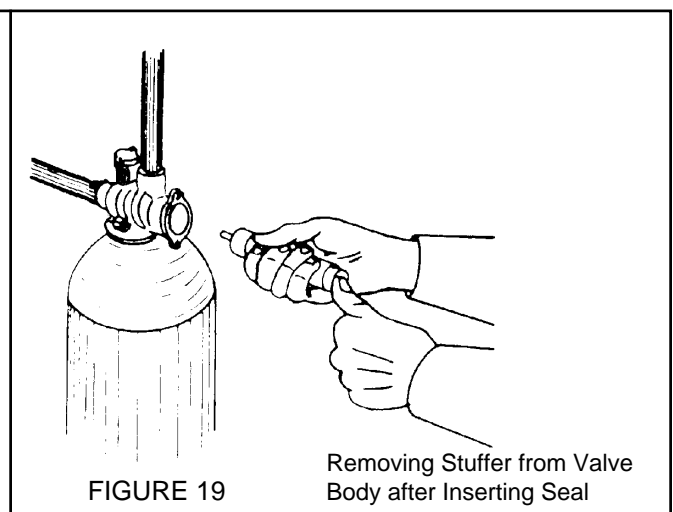
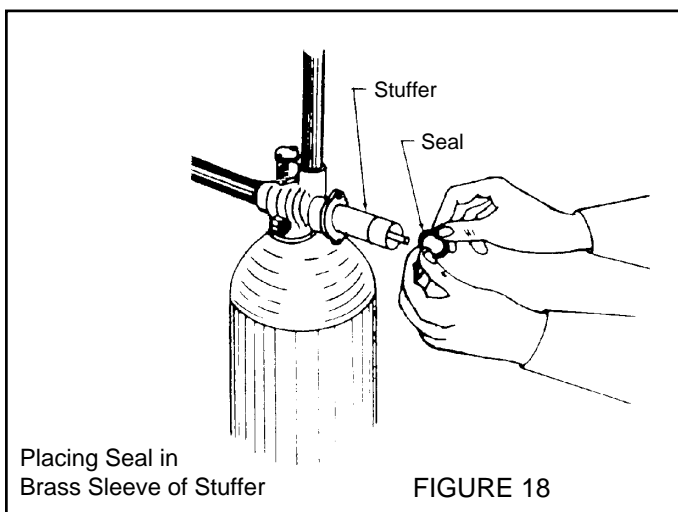
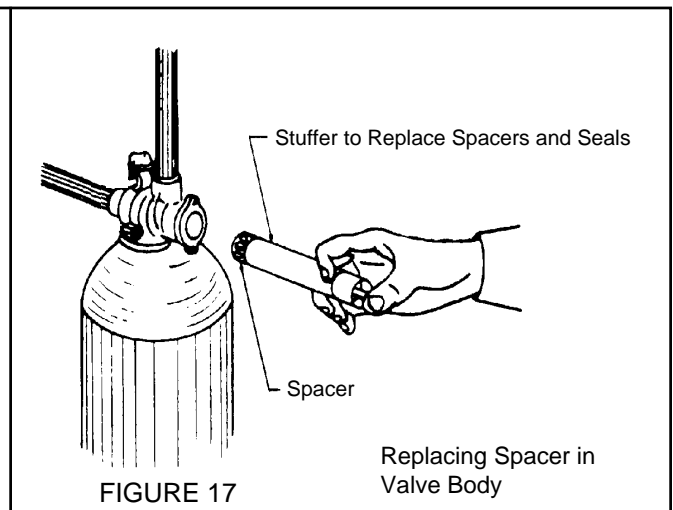
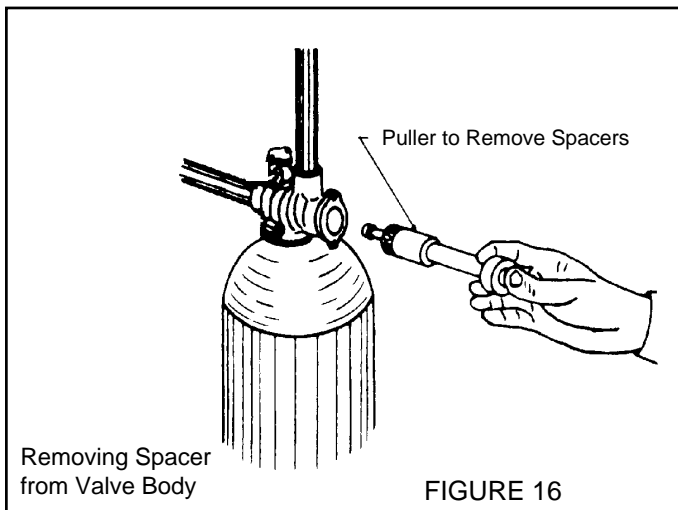

IRON CURTAIN FLOW DIAGRAMS

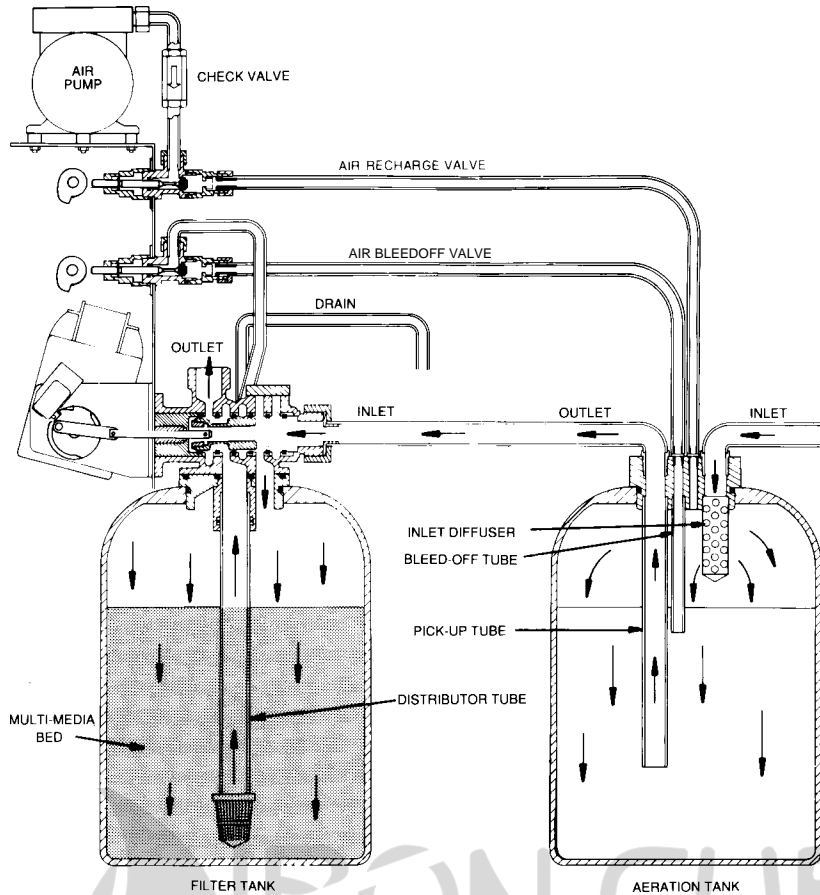

Step 1. Service Position

Raw water enters the aeration-tank inlet, flows thru the inlet diffuser, thru a head of air, down thru the aeration tank, thru the pick-up tube, out the aeration head, into the filter control inlet, and down thru the multi-media bed. Filtered water is collected by the bottom distributor, flowing up thru the distribution tube, and out the top of the filter control.

U.S. Patent #B1 5,096,596

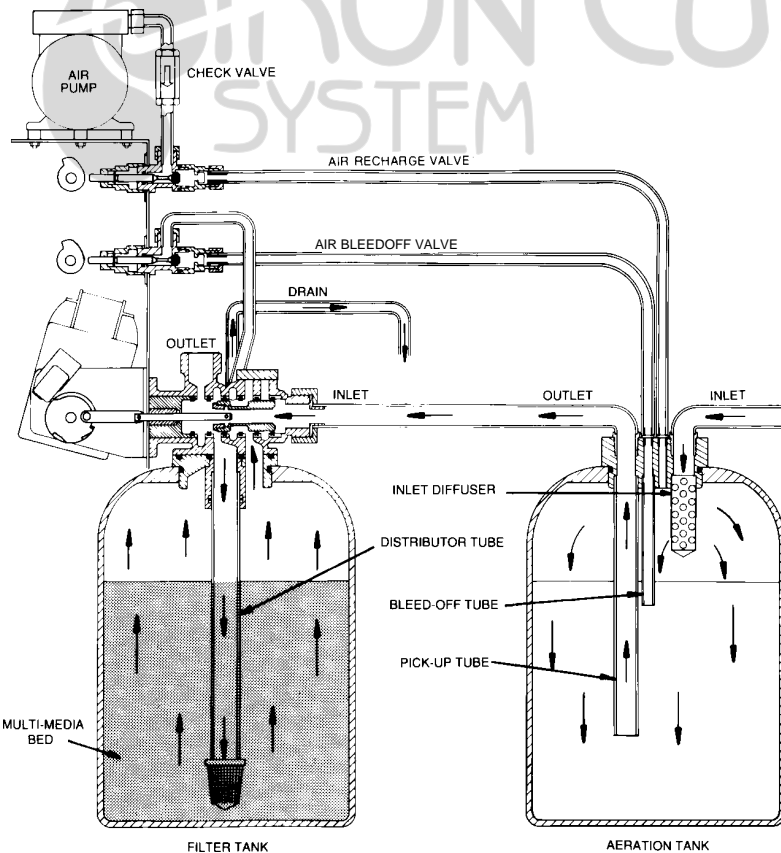

Step 2. Backwashing the Multi-Media Filter Bed

The Iron Curtain Control Center automatically shifts the controller into the backwashing cycle. Raw water enters the filter valve inlet from the aeration system, flows down thru the distribution system and up thru the multi-media bed, and out the drain line. The oxidized contaminants which were removed during the service cycle are backwashed out to the drain.

U.S. Patent #B1 5,096,596

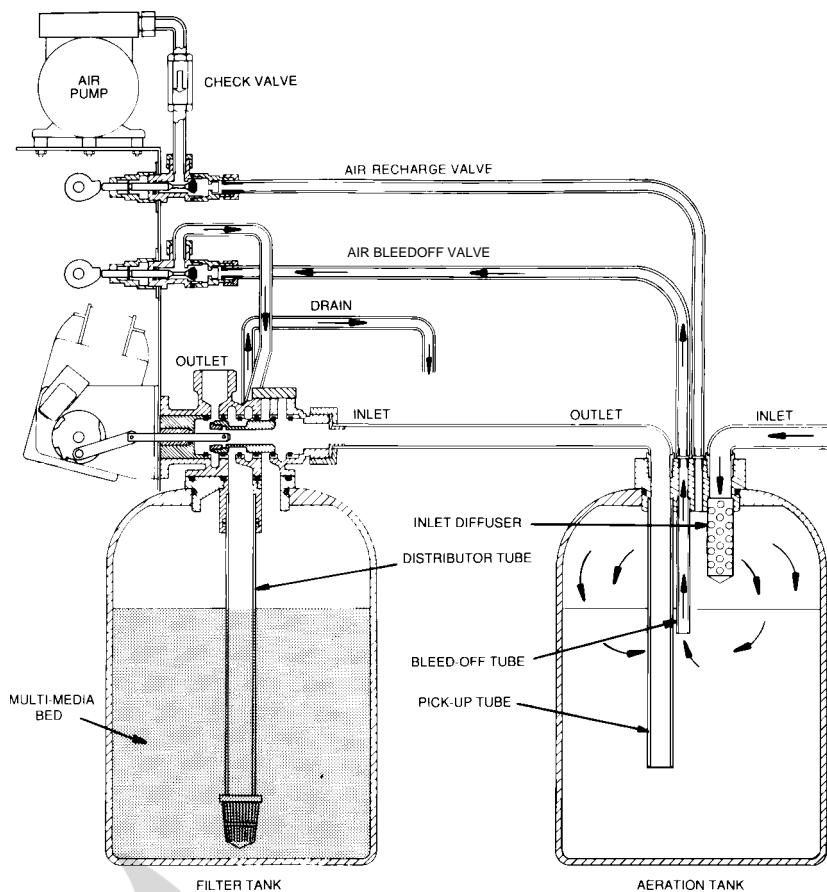

Step 3. Bleeding Off the Aeration System

The Iron Curtain Control Center automatically shifts the controller into the Aeration recharge cycle. The air bleedoff valve opens up and allows raw water and/or air to pass thru the bleed off tube in the aeration tank to the drain. The air recharge valve is also open during this time; however, a check valve prevents any backflow toward the compressor.

U.S. Patent #B1 5,096,596

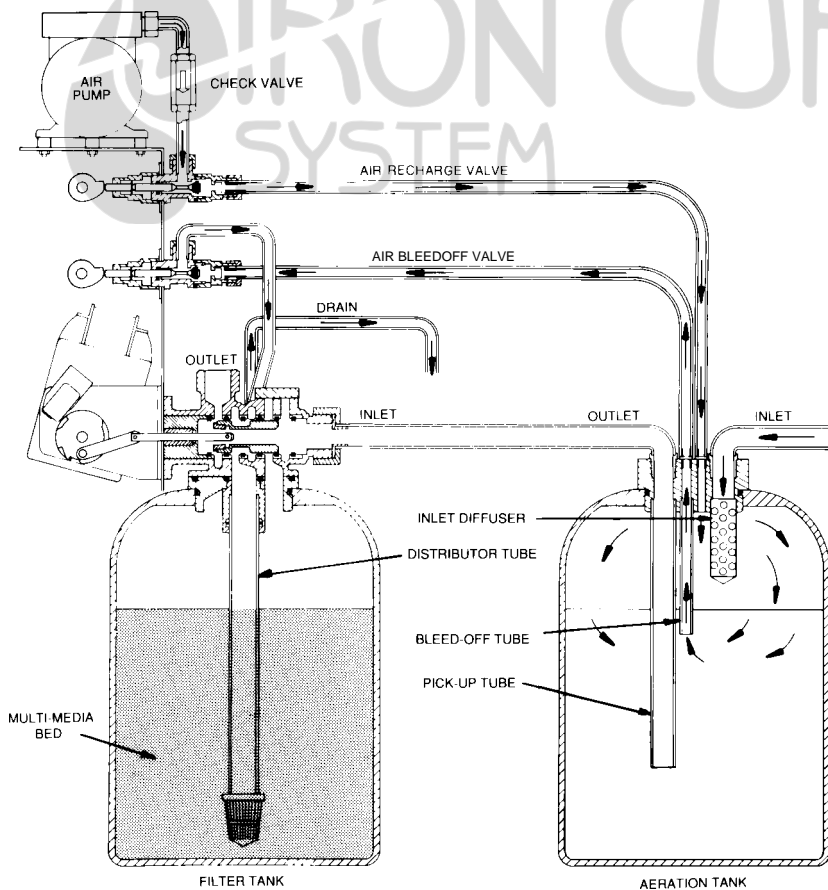

Step 4. Recharge of Aeration Tank with New Air

After approximately 2-4 minutes a specially mounted switch in the Iron Curtain Control Center turns the air compressor pump on for approximately 10 minutes. Water and/or air continue to run to the drain thru the air bleedoff valve and the compressor pumps air thru the air recharge valve, directly into the aeration tank. At the end of this cycle the aeration tank has been recharged with fresh air, and will have approximately an 18 inch head of air.

U.S. Patent #B1 5,096,596

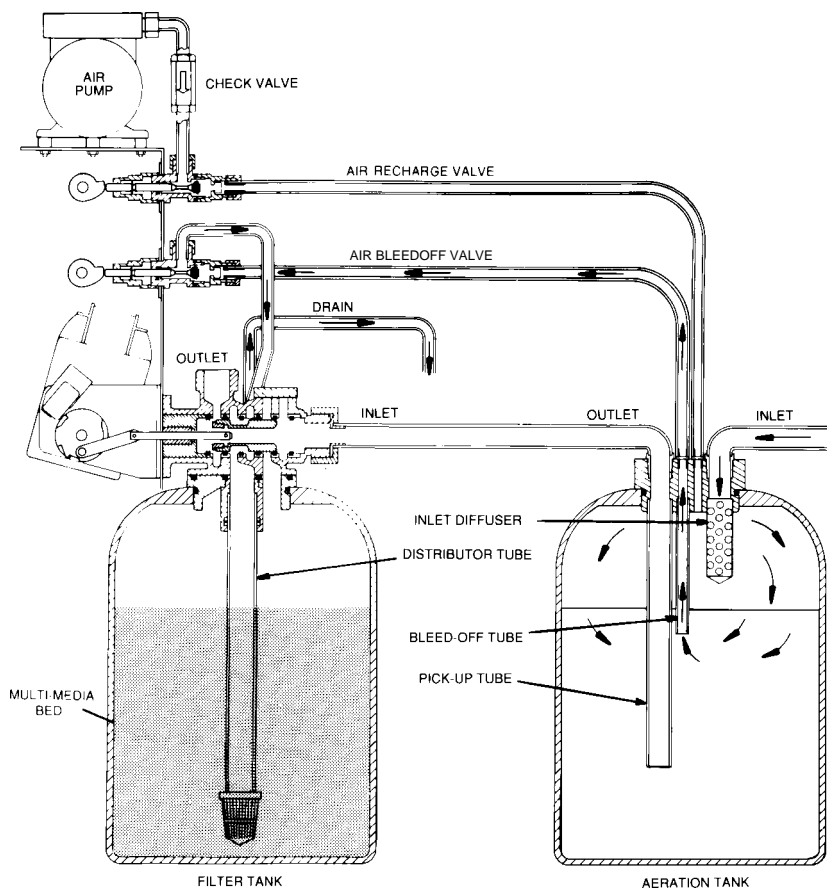

Step 5. Bleeding Off Excess Air

The Iron Curtain Control Center automatically turns the air compressor pump off and allows both valves to remain open. The air bleedoff valve will bleed off any excess air which was pumped in during the previous step and the check valve in the recharge line prevents any backflow into the air compressor system.

U.S. Patent #B1 5,096,596

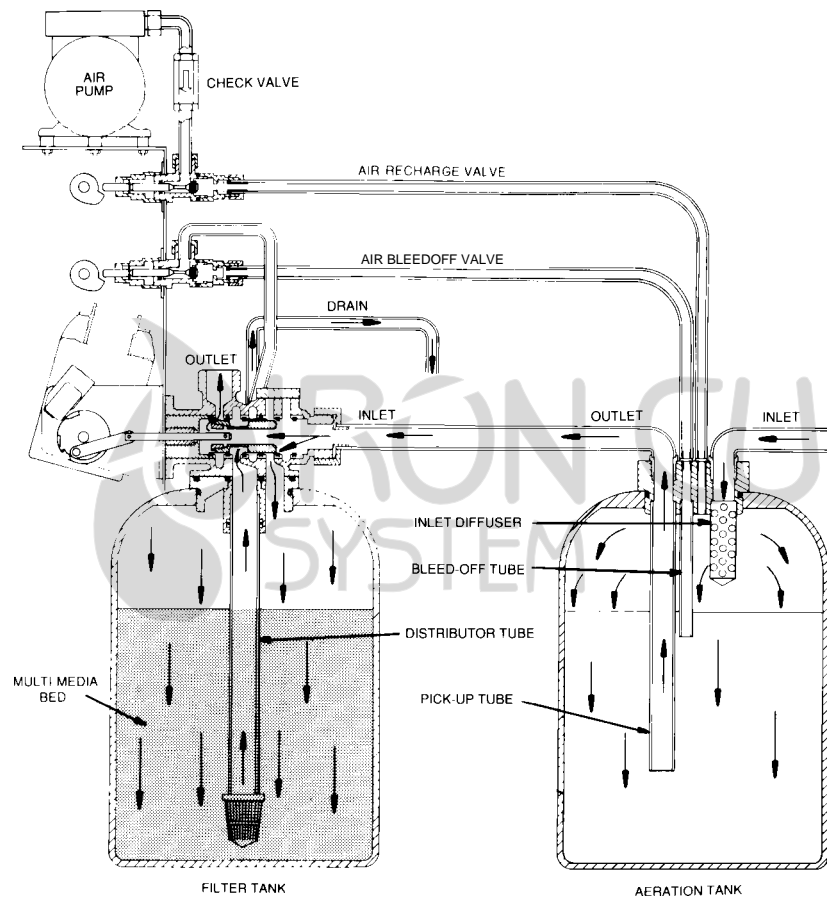

Step 6. Packing the Bed for Filtering

The Iron Curtain Control Center automatically closes both the air bleedoff and air recharge valves and shifts the piston into the rapid rinse position. Raw water passes thru the aeration system and enters the control valve, passes down thru the multi-media filter bed into the bottom distribution system, up thru the distributor tube, and out to the drain. At the end of this cycle the Iron Curtain System automatically returns to the service position.

U.S. Patent #B1 5,096,596

Troubleshooting

Complaint	Problem	Cause	Solution	
Iron or manganese* bleed-through or staining	A. Inadequate backwash of filter	1. Plugged drain line flow control	1a. Clean or replace drain line flow control	
		2. Insufficient water supply from well	2a. Check for minimum specified flow and pressure requirements of filter system	
		3. Plugged aeration tank inlet diffuser or pick-up tube	3a. (Generally will only plug with the presence of iron bacteria) Clean aeration assembly and shock treat the water supply with chlorine as needed to control iron bacteria	
		4. Media bed fouled	4a. Rebed filter and correct the cause of fouling	
Sulphur odor bleed-through	B. Fails to regenerate	1. Interrupted electrical service	1a. Assure continuous electrical supply (check plug, breaker, fuses, etc.)	
		2. Faulty timer motor	2a. Replace timer motor	
		3. Faulty skipper wheel	3a. Replace skipper wheel	
		4. Faulty 24 hour gear	4a. Replace 24 hour gear or timer assembly	
C. Water contaminant levels are greater than limits established by the manufacturer	1. It is not uncommon for local water conditions to change	1a. Consult factory		
D. Inadequate aeration	1. Loss of air through inlet check valve		1a. Check installation position of check valve – Consult Installation and Operation Manual for proper position	
			1b. Check for foreign material in seat of check valve, clean or replace as required	
	2. Loss of air through air leak		2a. Check aeration tank assembly and air recharge line and fittings for any air leaks and repair (Note: soapy water solution works well for locating air leaks)	
		3. Faulty aeration pump due to:	a. Electrical failure	3a. Assure permanent electrical service (check plug, breaker, fuses, terminal block on control valve, etc.)
			b. Pneumatic failure	3b. Check for adequate pressure and volume production from air pump. Repair or replace air pump
			c. Faulty air line check valve allowing water to back up through aeration pump during regeneration cycle	3c. Repair or replace check valve, and clean, repair or replace aeration pump
	d. Damp environment	3d. Clean, repair or replace aeration pump, ventilate environment or provide external air source		
	4. Air loss through high demand		4a. Increase regeneration frequency of filter or Iron Curtain Remote Control Center	
	E. Exceeding recommended filter system flow rate	1. Service flow rate demand is higher than filter system design flow rate	1a. Install a flow control at filter system outlet equal to or less than the design flow rate of filter system	
		1b. Install additional filter(s) or a larger single filter system which meets both the service flow demand and backwash flow requirements available		
F. Regeneration during service flow demand	1. Time of day set incorrectly	1a. Reset timer		
G. Raw water bleeding through filter	1. Internal control valve leak		1a. Assure all adapter base o-ring seals are in place	
			1b. Replace seals, spacer and piston assemblies	

*Manganese can be slow to oxidize when the pH is less than 8.5

Complaint	Problem	Cause	Solution
Water leaking from relief valve	A. Dirt lodged under seat of valve	1. Pressure has exceeded rating on relief valve and caused valve to open	1a. Check pressure on system. Adjust if necessary. Clean or replace relief valve.
	B. Faulty or defective relief valve		1a. Replace valve
Water is effervescent	A. This can be expected when water is aerated under pressure	1. Water supply has been naturally aerated under well system pressure. As water is released to the atmosphere, air molecules separate from the water molecules.	1a. This natural phenomenon will typically dissipate to the atmosphere in a matter of seconds. If preferred, water can be drawn and stored in an open container prior to use (i.e. fill a pitcher and store in the refrigerator for cool fresh drinking water)
Loss of pressure	A. See complaint #1 problem A & B		
Air spurting at outside or non-filtered water fixtures	A. Inlet check valve not sealing	1. Improper installation location	1a. See installation and operation manual for proper location of inlet check valve
		2. Foreign material preventing check valve from sealing	2a. Clean or replace check valve
		3. Worn or faulty check valve	3a. Replace check valve
Air spurting from filtered water fixtures	A. Reduced pressure in distribution system	1. Service flow demand is greater than water supply available from well pump system	1a. Repair or replace well pump system
		2. Water flow is restricted by supply piping and/or water treatment equipment	2a. Eliminate restrictions in supply pipings to water treatment equipment such as iron bacteria plugging the upper diffuser assembly, etc.
			2b. Install larger water treatment system to provide less pressure drop
Loss of media through drain line	A. New filter backwashed during first 24 hours after installation	1. New filter media is shipped in a dry condition and must soak for 24 hours to become fully saturated before a backwash cycle	1a. Clean drain line flow control, control valve body, seals, spacers and piston assemblies
	B. Air passing through filter during backwash	1. Excess air accumulated in aeration tank from aeration pump	1a. Bleed-off valve flow control is plugged with foreign material – clean or replace
		2. Excess air accumulated in filter system from water supply or well pump	2a. Repair well pump system 2b. If the cause was due to temporary loss of water main pressure; the problem will most likely correct itself with the return of continuous pressure
Excessive noise during regeneration	A. Howling or whistling noise during regeneration cycle	1. Inadequate drain line size	1a. Increase drain line size
		2. Drain line is vibrating against other pipes, conduits, pipe hangers, heat ducts, floor joists, etc.	2a. Insulate drain line, specifically at points of contact with other materials
Water running to drain continuously	A. Control valve is stuck in regeneration cycle	1. Electrical service to control(s) has been interrupted	1a. Assure continuous electrical service is available (check plug, breaker, fuse, etc.)
		2. Faulty timer motor	2a. Replace timer motor
		3. Foreign material lodged in piston	3a. Disassemble and clean control valve, replace seals, spacers, and piston assemblies
		4. Timer is lodged in regeneration cycle	4a. Check program wheel pins, to assure back pins are not catching on timer gears 4b. Check to assure timer gears are clean and free from foreign materials such as solder or pipe burrs
Blue green staining	A. Corrosive water condition in copper distribution piping system	1. Low pH condition of the raw water supply. On type "A" filters, the pH correction media may be depleted	1a. On type "A" filters add pH correction media to filter tank, see Installation and Operation manual
		2. In rare occasions, highly aerated water in combination with a specific water supply can create a slightly corrosive condition	2a. Install a polyphosphate cartridge filter after the Iron Curtain Filter System to protect the distribution piping

Winterizing Iron Curtain Systems (Optional)

In certain climates where houses and/or cottages are not heated during the winter months, Iron Curtain Systems must have the water removed from them to protect from damage due to freezing. Following are instructions for "winterizing" Iron Curtain Systems.

Prior to draining water distributor system and Iron Curtain System, manually initiate regeneration of Iron Curtain System (see page 10) and allow system to complete regeneration and return to service position automatically.

Draining of the Iron Curtain System should be done in conjunction with or after the complete water distribution system is drained to prevent water from entering the Iron Curtain System after it has been winterized. After Iron Curtain System and water distribution system are drained, make sure all water shut-off valves are open.

Instructions for winterizing Iron Curtain Systems:

1. After water distribution system is drained, place Iron Curtain System on bypass. (See Figures 1, 2 & 3 on page 8)
2. Manually advance the timer to rapid rinse position. (See page 10) Unplug power cord.
3. After pressure is relieved, disconnect white air recharge line from aeration head.
4. With an air compressor, blow air through white air recharge fitting in aeration head until air with little or no water discharges to drain.

Caution: Use only enough air pressure to force water in tank to discharge. Do not exceed 30 psi.

5. It is recommended at this point to disconnect the inlet/outlet of aeration tank and remove the aeration head assembly. Dump remaining water. If aeration head assembly has a buildup of iron bacteria, the well should be shock treated with chlorine when the water system is reactivated. Consult your local dealer for more information regarding shock treating the well. Clean aeration head assembly of any buildup and reassemble aeration tank.
6. Plug in power cord and manually advance the timer to service position and allow control valve to reset to service position. Manually advance timer to backwash position, then to air recharge position. (See pages 10) Unplug power cord.
7. Open inlet & outlet shut-off valves. Leave bypass valve open.
8. System is now winterized.
9. When turning system back on, follow start up instructions on page 6.

Instructions for Iron Curtain Systems with filter tank equipped with optional bottom drain assembly:

1. After water distribution system is drained, place Iron Curtain System on bypass. (See Figures 1, 2 & 3 page 8)

Unplug power cord.

2. Open the bottom drain valve on the Iron Curtain filter tank and allow water to drain out. You may want to connect a garden hose to drain valve and run to appropriate drain. Leave drain valve open.
3. After pressure is relieved, disconnect white air recharge line from aeration head.
4. With an air compressor, blow air through white air recharge fitting in aeration head until air with little or no water discharges from drain valve.

Caution: Use only enough air pressure to force water in tank to discharge. Do not exceed 30 psi.

- 5A. **If aeration tank IS NOT equipped with optional bottom drain:** It is recommended at this point to disconnect the inlet/outlet of aeration tank and remove the aeration head assembly. Dump remaining water. If aeration head assembly has a buildup of iron bacteria, the well should be shock treated with chlorine when the water system is reactivated. Consult your local dealer for more information regarding shock treating well. Clean aeration head assembly of any buildup and reassemble aeration tank.
- 5B. **If aeration tank IS equipped with optional bottom drain:** Open the bottom drain valve on the Iron Curtain aeration tank and allow water to drain out. You may want to connect a garden hose to drain valve and run to an appropriate drain. Leave drain valve open.
6. Plug in power cord and manually advance timer to backwash position, then to air recharge position. (See page 10) Unplug power cord.
7. Open inlet and outlet shut-off valves. Leave bypass valve open.
8. System is now winterized.
9. When turning system back on, follow start up instructions on page 6. Note: The bottom drain valve on Iron Curtain aeration tank and filter tank must be closed prior to start up.

CAUTION: Always be certain that the distribution piping, including but not limited to, the bypass piping arrangement typically just above the Iron Curtain System does not trap water that may consequently drain into the filter after the filter draining procedure is complete and all pressure is relieved. If optional drain valve(s) are used, it is suggested they be left open.

IRON CURTAIN FILTER SYSTEMS LIMITED WARRANTY

Hellenbrand, Inc., warrants to the original consumer/purchaser against defects in material and/or workmanship from the date of the original installation as follows:

For a Period of **FIVE YEARS**: The 3/4" or 1" control valve(s) including electrical parts, internal parts, and valve body.

For a Period of **TEN YEARS**: The fiberglass and/or polyglass mineral tanks, 6" Diameter – 13" Diameter.

For a Period of **FIVE YEARS**: The fiberglass and/or polyglass mineral tanks, 14" Diameter – Up.

For a Period of **ONE YEAR**: The Iron Curtain aeration pumps and any other defective component.

Any parts used for replacement are warranted for the remainder of the original warranty period.

If a part described above becomes defective within the specified period, you should notify your Hellenbrand Iron Curtain reseller and arrange a time during normal business hours for the Iron Curtain reseller to inspect the water conditioner on your premises. Any part found defective within the terms of this warranty will be replaced by him. You pay only freight from our factory and local Iron Curtain reseller charges.

THIS WARRANTY DOES NOT COVER defects caused by accident, fire, flood, Act of God, misuse, misapplication, neglect, alteration, installation or operation contrary to our printed instructions, or repair or service by anyone other than the factory or authorized Hellenbrand Iron Curtain reseller.

EXCEPT AS EXPRESSLY PROVIDED ABOVE, HELLENBRAND MAKES NO OTHER WARRANTY WITH RESPECT TO THE IRON CURTAIN FILTER SYSTEM WHETHER EXPRESS OR IMPLIED, INCLUDING THE IMPLIED WARRANTIES OF MERCHANTABILITY AND FITNESS FOR A PARTICULAR PURPOSE, WHICH BUT FOR THIS PROVISION MIGHT ARISE BY IMPLICATION OR OPERATION OF LAW; ALL SUCH WARRANTIES ARE HEREBY EXPRESSLY DISCLAIMED.

Our performance specifications are furnished with each water conditioning unit. As a manufacturer, we do not know the characteristics of your water supply or the purpose for which you are purchasing this water conditioner. Please understand the quality of water supplies may vary seasonally or over a period of time, and that your water usage may vary as well. Water characteristics can also change considerably if your water conditioner is moved to a new location. For these reasons, we assume no liability for the determination of the proper equipment necessary to meet your requirements and we do not authorize others to assume such obligations for us.

UNDER NO CIRCUMSTANCES SHALL HELLENBRAND, INC., BE LIABLE TO PURCHASER OR TO ANY OTHER PERSON FOR ANY INCIDENTAL, SPECIAL, OR CONSEQUENTIAL DAMAGES OR FOR ANY OTHER LOSS, DAMAGE, OR EXPENSE OR ANY KIND, INCLUDING LOSS OF PROFITS, WHETHER ARISING OUT OF BREACH OF WARRANTY, BREACH OF CONTRACT, OR OTHERWISE.

Some states do not allow the exclusion or limitation of incidental or consequential damages, so the above limitation or exclusion may not apply to you. This warranty gives you specific legal rights, and you may also have other rights which vary from state to state.

Updated January 2003